

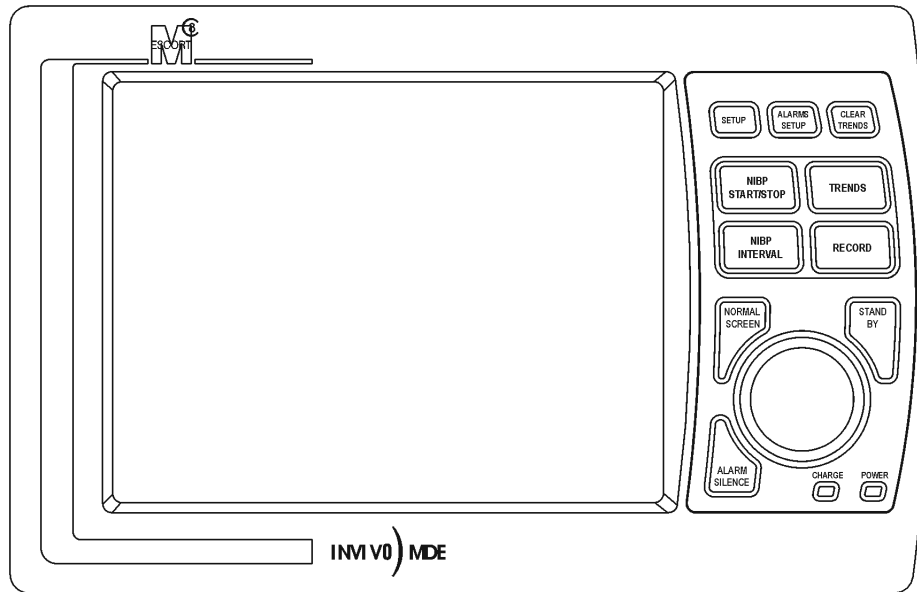

9566

Escort™ M8 Patient Monitor



Service Manual

InvivoMDE
An Intermagnetics Company



Invivo Research, Incorporated
Orlando, FL 32826

Escort M8 Vital Signs Monitor Service Manual
Part Number 9566, Release 1.

Invivo Research 2004 All Rights Reserved
Printed in the United States of America

The information in this document is subject to change without notice.

This document contains proprietary information that is protected by copyright. No part of this document may be reproduced in any manner, in whole or in part (except for brief excerpts in reviews and scientific papers) without the prior written consent of Invivo Research.

Invivo Research makes no warranty of any kind on this material, including but not limited to, the implied warranties of merchantability and fitness for a particular purpose. Invivo Research shall not be liable for errors contained herein or for incidental or consequential damages concerning the furnishing, performance or use of this material.

Invivo Research monitoring devices are intended for use only by qualified medical personnel.

Before using any Invivo Research monitoring device, be sure to read carefully and understand all manuals provided with the device.

CAUTION - United States Federal law restricts this device to sale by or on the order of a physician.

Manufactured by:
InvivoMDE
12601 Research Parkway
Orlando, FL 32826

European Authorized Representative

Invivo Research UK, Ltd.
Halifax, West Yorkshire
United Kingdom



User Assistance

If you have a question or need help operating the Escort M8 Vital Signs Monitor, please contact InvivoMDE Technical Service:

US: (888) 221-1593

Int'l: (407) 275-3220

For the latest information about InvivoMDE products, please consult our web site:

www.intermagnetics.com

Table of Contents

<u>Paragraph Number</u>	<u>Page Number</u>
General Information.....	vi
Precautions.....	ix
Patents and Licensing.....	xiv
1. OVERVIEW.....	1-1
1.1 Escort M8 Vital Signs Monitor Diagrams.....	1-1
1.2 Escort M8 Vital Signs Monitor User Interface.....	1-4
1.3 Main Features of the Escort M8 Vital Signs Monitor.....	1-5
2. INSTALLATION AND CHECKOUT.....	2-1
2.1 Preinstallation.....	2-1
2.2 How to Connect the Escort M8 Vital Signs Monitor to Power.....	2-1
2.2.1 Operational Checkout Procedure.....	2-2
3. CONFIGURING THE MONITOR.....	3-1
3.1 System Setup.....	3-1
3.1.1 Setup Menu.....	3-1
3.1.2 Setup Biomedical Menu.....	3-1
4. BATTERY OPERATION.....	4-1
5. FUNCTIONAL VERIFICATION.....	5-1
6. TROUBLESHOOTING.....	6-1
6.1 Power-up Malfunctions.....	6-1
6.1.1 Display Is Blank At Power-Up (No Power LED Illuminated).....	6-1
6.1.2 Display Is Blank At Power-Up (with Power LED Illuminated).....	6-1
6.1.3 Monitor Only Displays the Power-Up (“Invivo)MDE M8”) Banner.....	6-2
6.1.4 Power-Up Banner Is Followed by A Blank Screen.....	6-3
6.1.5 Monitor Does Not Run on Battery Power.....	6-3
6.2 Physiological Monitoring Malfunctions.....	6-3
6.2.1 Monitor Won’t Display an ECG or Respiration Signal.....	6-3
6.2.2 Monitor Displays Constant ECG Pacer Annotations.....	6-4
6.2.3 Monitor Displays an “SPO2 Replace Sensor” Message.....	6-4
6.2.4 Monitor Displays a “Temp Needs Service” Message.....	6-4
6.2.5 Monitor Displays an “NBP Needs Service” Message.....	6-4
6.3 Non-Physiological Monitoring Malfunctions.....	6-5
6.3.1 Optional Recorder Not Working.....	6-5
6.3.2 Missing Rows or Sections of Display Pixels.....	6-6
6.3.3 Other Technical Messages.....	6-6
6.4 Reducing EMI.....	6-6
7. REPAIR.....	7-1
7.1 External Chassis Components.....	7-2
7.2 Functional Block Diagram.....	7-3
7.3 Cable Interconnection/Wiring Diagram.....	7-4

Table of Contents (Continued)

<u>Paragraph Number</u>	<u>Page Number</u>
7.4 Major Assembly Views	7-5
7.4.1 Assembly/Subassembly Views	7-7
7.5 Monitor Disassembly Procedure.....	7-14
7.6 Monitor Reassembly Procedure.....	7-14
7.7 Replacing the Display.....	7-14
7.8 Replacing the Optional Recorder Assembly.....	7-14
7.9 Replacing the SPO2 Masimo Board.....	7-15
7.10 Replacing the Power Supply Board.....	7-15
7.11 Replacing the Battery Charger Board.....	7-15
7.12 Replacing Cracked Case Pieces.....	7-15
8. ACCESSORIES	8-1
9. SPARE PARTS	9-1
10. CLEANING.....	10-1
11. MAINTENANCE AND STORAGE.....	11-1
11.1 Battery Replacement.....	11-3
11.2 Storage	11-4
11.3 Warranty	11-4
11.4 Password Control.....	11-4
12. DISPOSAL	12-1
13. TECHNICAL DATA.....	13-1

List of Figures

<u>Figure Number</u>		<u>Page Number</u>
1-1	Escort M8 Vital Signs Monitor - Front View	1-1
1-2	Escort M8 Vital Signs Monitor - Left Rear View	1-2
1-3	Escort M8 Vital Signs Monitor - Right Rear View	1-2
1-4	Escort M8 Vital Signs Monitor - Left Side View	1-3
1-5	Front Panel Keypad	1-4
1-6	Example of Escort M8 Vital Signs Monitor Normal Screen	1-5
2-1	Escort M8 Vital Signs Monitor Normal Screen.....	2-2
3-1	Setup Menu	3-1
3-2	Setup Biomedical Menu.....	3-1
3-3	Setup Configuration Menu.....	3-2
3-4	Enter Password Menu	3-2
3-5	Setup Alarm System Menu	3-3
3-6	Setup System Menu	3-4
3-7	Setup Service Menu	3-4
4-1	Normal Screen Showing Battery Icon	4-1
7-1	External Chassis Components	7-2
7-2	M8 Overall Functional Block Diagram	7-3
7-3	M8 Cable Interconnection/Wiring Diagram	7-4
7-4	Monitor Major Assembly View	7-5
7-5	Battery Cover Major Assembly View	7-6
7-6	Battery Cover Assembly View	7-7
7-7	Monitor Front Bezel Assembly View A (Rear).....	7-8
7-8	Monitor Front Bezel Assembly View B (Front).....	7-9
7-9	Monitor Rear Case Assembly View	7-10
7-10	Input Panel Assembly View	7-11
7-11	Recorder Subassembly View	7-12
7-12	Input Panel Subassembly View	7-13



General Information

This Service Guide provides information for the Invivo Research Escort M8 Vital Signs Monitor. The Escort M8 Vital Signs Monitor is a small, lightweight patient monitor designed to acquire and display physiological waveforms and parameters.

Before using the Escort M8 Vital Signs Monitor, be sure to read carefully and understand all sections of this Service Guide. Failure to read and understand the instructions may lead to misuse of the Escort M8 Vital Signs Monitor, which could result in harm to the patients.



Typographical Conventions in this Service Guide

This guide contains warnings, cautions and notes to help call your attention to the most important safety and operational aspects of the system. To help identify these items when they occur in the text, they are shown using the following typographical conventions:

WARNING - Statements that call attention to the possibility of injury, death or other serious adverse reactions associated with the use or misuse of the device.

CAUTION - Statements that call attention to the possibility of a problem with the device associated with its use or misuse. Such problems include device malfunction, device failure, damage to the device or damage to other property.

NOTE - Statements that provide supplemental information.



Indications for Use

The Escort M8 Vital Signs Monitor is indicated for use in adult and pediatric patient populations in an environment where patient care is provided by healthcare professionals (e.g. Physician, Nurse, Technician) when:

1. The professional determines that a device is required to measure any or all of the following patient parameters:
 - Heart Rate
 - Respiration Rate
 - Temperature
 - Systolic, Mean and Diastolic Blood Pressure
 - Functional Oxygen Saturation of Arterial Hemoglobin (SpO₂)
 - Pulse Rate

And,

2. The professional determines that a device is required to issue visible and audible alarms when any or all of the following parameters exceed preset limits:
 - Heart Rate
 - Respiration Rate
 - Temperature
 - Systolic, Mean and Diastolic Blood Pressure
 - Functional Oxygen Saturation of Arterial Hemoglobin (SpO₂)
 - Pulse Rate

Precautions

General

Electrosurgery. The Escort M8 Vital Signs Monitor is suitable for use in the presence of electrosurgical (ESU) equipment. The following precautions should be taken:

- To minimize the risk of patient burns, only use ESU equipment that monitors the impedance of the ESU return wires.
- Users should be properly trained in the operation of the ESU equipment.
- Keep patient applied cables (e.g. ECG lead wires) off of earth ground and away from the ESU knife and return wires.
- Only use Invivo Research recommended accessories.
- While cutting, use the SpO2 parameter instead of the ECG parameter to determine heart rate.

Alarm Monitoring. Failure to respond to alarms that are annunciated by the Escort M8 Vital Signs Monitor will cause a lapse in patient monitoring. Always respond promptly to alarms.

Flammable Anesthetics. An explosion hazard exists if the monitor is used in the presence of flammable anesthetics.

Anesthesia Patients. Constant attention by a qualified individual is needed whenever a patient is under anesthesia or connected to a ventilator.

Device Interconnections. Through its Network Connector port, the Escort M8 Vital Signs Monitor can be connected to external devices. The following precautions should be taken:

- The Network Connector cable should not be applied to the patient.
- Connected devices should be located outside of the patient vicinity (greater than 1.5 meters) if they do not comply with IEC 60601-1.
- The Escort M8 Vital Signs Monitor should not be connected to devices that are not described in this manual.
- The over-all system leakage current should be tested and should comply with IEC 60601-1-1.

Do not operate the Escort M8 Vital Signs Monitor near high frequency emissions (e.g. microwaves).

Single use devices should not be reused.

The accuracy of the measurements can be affected by the position of the patient, the patient's physiological condition, and other factors. Always consult a physician for interpretation of measurements made by this monitor.

If any system failure occurs (e.g. an unexplained continuous audible alarm) remove the monitor from use, and refer it to qualified service personnel.

Perform operational checkout before each use. If monitor fails to function properly, refer to qualified service personnel.

For safe and accurate operation, use only recommended Invivo Research patient cable, lead wires, cuffs, hoses, sensors, tubing, etc. A listing of these can be found in the Accessory Listing within this manual, or by contacting Invivo Research directly.

The system may not conform to all performance specifications if stored or used outside the environmental specifications identified in Section 12.

For proper equipment maintenance, perform the service procedures at the recommended intervals as described in the monitor's service manual.

Precautions

Electrical Safety

If monitor becomes accidentally wet during use, discontinue operation of the monitor until all affected components have been cleaned and permitted to dry completely. Contact your local Invivo Research, Inc. representative if additional information is required.

Shock hazard exists if operated without chassis cover. Refer servicing to qualified service personnel only.

For continued protection against fire hazard, replace fuses with same type and rating only.

Connect the monitor only to a three-wire, grounded, hospital-grade receptacle. The three-conductor plug must be inserted into a properly wired three-wire receptacle; if a three-wire receptacle is not available, a qualified electrician must install one in accordance with the governing electrical code.

Do not under any circumstances remove the grounding conductor from the power plug.

Avoid use of electrical power extension cords. Electrical power extension cords may create a safety hazard by compromising the grounding integrity of the monitor.

This monitor and its listed accessories may be safely powered by the voltages 110-120/220-240 VAC having a frequency of 50 or 60 Hz.

If the integrity of the earth ground conductor of the AC mains power cable is in doubt, operate the monitor on internal battery power until proper earth ground connection is confirmed.

Patient Safety

As with all medical equipment, carefully route patient cabling to reduce the possibility of patient entanglement or strangulation.

ECG

Pacemaker Patients. Rate meters may continue to count the pacemaker rate during occurrences of cardiac arrest or some arrhythmias. Do not rely entirely upon rate meter alarms. Keep pacemaker patients under close surveillance. See the Technical Data chapter for disclosure of the pacemaker pulse rejection capability of this instrument.

Arrhythmia Patients. The Escort M8 Vital Signs Monitor is designed to operate in the presence of cardiac arrhythmias. However, the heart rate meter may be adversely affected in some cases.

An inoperative ECG monitor is indicated by absence of an ECG waveform and a simultaneous Lead Fail alarm.

For best ECG, Heart Rate, S-T Segment, and/or Respiration monitoring, always select the optimum lead configuration which has the least artifact and largest waveform(s) being detected for monitoring use.

NIBP

Always use recommended NIBP cuffs and hoses. Avoid compression or restriction of NIBP cuff hose.

When using the NIBP portion of this instrument to measure blood pressure, remember that the patient's blood pressure readings are not continuous, but are updated each time a blood pressure measurement is taken. Set a shorter interval for more frequent updating of the patient's blood pressure.

Do not attach the cuff to a limb being used for infusion. Cuff inflation can block infusion, possibly causing harm to the patient.

Frequent NIBP measurements can cause pooling of the blood in the limb (hemostasis), and peripheral tissue/nerve damage. Allow sufficient time between measurements for blood recirculation to prevent pooling of the blood in the limb.

Precautions

NIBP (Continued)

Arrhythmic and/or erratic heart beats (or severe motion artifact, such as tremors or convulsions) can result in inaccurate readings and/or prolonged measurements. If questionable readings are obtained, re-check patient's vital signs by alternate means before administering medication.

To prevent possible nerve damage to the limb, apply the NIBP cuff as recommended by current American Heart Association (AHA) guidelines for blood pressure monitoring.

To ensure accurate and reliable measurements, use only recommended patient cuffs/hoses. For best accuracy, use the appropriate cuff size for each patient as recommended by the current AHA guidelines for blood pressure monitoring.

Some reusable NIBP cuffs contain a medical-grade latex rubber. Patients sensitized to latex rubber can have an allergic reaction when exposed to this material. Avoid the use of cuffs which contain latex rubber on patients who are allergic to this material.

Routinely inspect the cuff and hose assemblies for proper attachment and orientation. Replace cuff and/or hose assemblies with cracks, holes, tears, cuts, etc. that could cause leaks in the system. If cuff and/or hose assemblies with damage which could result in leaks are used, prolonged and/or inaccurate patient readings could result.

SpO2

Avoid placement of the SpO2 sensor on the same limb with an inflated blood pressure cuff. Cuff inflation could result in inaccurate readings and false alarm violations.

SpO2 monitoring requires the detection of valid pulses to correctly determine SpO2 and Heart Rate values. During conditions of gross artifact, or in the absence of valid pulses, the SpO2 /rate values may not be correct.

The SpO2 monitoring portion of this monitor is intended to measure arterial hemoglobin oxygen saturation of functional hemoglobin (saturation of hemoglobin functionally available for transporting oxygen in the arteries). Significant levels of dysfunctional hemoglobins, such as carboxyhemoglobin or methemoglobin, may affect the accuracy of the measurement. Also, Cardiogreen and other intravascular dyes may, depending on their concentration, affect the accuracy of the SpO2 measurement.

Always shield the SpO2 sensor from extraneous incident light sources. Such extraneous light can cause SpO2 reading or pulse detection errors.

The numeric measurement values are updated every 1 second on the monitor display.

A pulse oximeter should be considered an early warning device. As a trend towards patient deoxygenation is indicated, blood samples should be analyzed by a laboratory co-oximeter to completely understand the patient's condition.

Use of this monitor may interfere with magnetic resonance imaging (MRI) procedures.

The pulse oximeter feature in this monitor is designed to display functional SpO2 values.

The pulse oximeter pulsatile waveform is not proportional to the pulse volume, but adjusts the waveform amplitude as needed for proper viewing.

Arrhythmic and/or erratic heart beats (or severe motion artifact, such as tremors or convulsions) can result in inaccurate readings and/or prolonged measurements. If questionable readings are obtained, re-check patient's vital signs by alternate means before administering medication.



Precautions

Temperature (SureTemp® PLUS)

To obtain accurate and reliable temperature measurements and to ensure patient safety, it is important that this manual be read thoroughly prior to use of the module, probe and accessories.

Use single-use Welch Allyn disposable probe covers to limit patient cross-contamination. The use of any other probe cover may produce temperature measurement errors or may result in inaccurate readings.

Do not take a patient's temperature without using a Welch Allyn disposable probe cover. Doing so can cause patient discomfort, patient cross-contamination, and erroneous temperature readings.

Long-term continuous monitoring (beyond five minutes) is not recommended.

Biting the probe tip while taking a temperature may result in damage to the probe.

To ensure patient safety and accurate temperature measurement, use only Welch Allyn accessories and supplies.

This equipment is not suitable for use in the presence of a flammable anesthetic mixture with air, oxygen, or nitrous oxide. The probe and connector are not waterproof. Do not immerse or drip fluids on these items. Should immersion or wetting occur, dry the device with warm air and then check all functions for proper operation.

The Welch Allyn **SureTemp® PLUS** probe consists of high-quality precision parts. Protect it from severe impact and shock. A qualified service technician must check any **SureTemp® PLUS** probe which is dropped or damaged to ensure proper operation prior to further use. Do not use the probe if you notice any signs of damage.

Do not autoclave. To prevent damage to the module, probe, and accessories, refer to the cleaning procedures described in Section 10.

Precautions

Other

This product, or any of its parts, should not be repaired other than in accordance with written instructions provided by InvivoMDE, or altered without prior written approval of Invivo Research Inc.

The user of this product shall have the sole responsibility for any malfunction which results from improper use, faulty maintenance, improper repair, damage, or alteration by anyone other than Invivo Research Inc., or its authorized service personnel.

This monitor is equipped with a demonstration mode which displays simulated electronic patient data for training or demonstration purposes. Do not attach a patient to the monitor whenever this simulation is present on the monitor display (“Simulated data” can also be seen in the message area of the normal screen). Failure to properly monitor the patient could result. Access is only available with the use of the Service Passord. To exit this mode, the Simulation Mode is set to Off in the Setup Service menu then the monitor must be powered off.

The patient connector inputs for all parameters are protected against the use of a defibrillator by internal circuitry, and when the recommended patient cables or accessories are used. The use of this circuitry and these recommended cables and accessories also protects against the hazards resulting from use of high frequency surgical equipment.

There are no known electromagnetic or other hazardous interference between the monitor and other devices. Medical equipment requires special precautions regarding EMC and must be installed, and put into service, according to the EMC information provided in the Operations Manual. However, care should be taken to avoid the use of cellular phones or other unintended radio-frequency transmitters in the proximity of the monitoring system.

Portable and mobile RF communications equipment can affect medical electrical equipment.

This monitor uses rechargeable batteries that contain lithium. These batteries must be recycled or disposed of properly. For proper disposal methods, contact your local InvivoMDE representative or distributor.

Dispose of the monitor and parts thereof according to local regulations.

Battery Handling. The Escort M8 Vital Signs Monitor contains a lithium ion coin cell battery and a transport battery pack. The following precautions should be taken regarding these batteries:

- Do not immerse in water.
- Do not heat or throw in fire.
- Do not leave in conditions over 60 °C or in a heated car.
- Do not attempt to crush or drop.
- Follow the instructions in the disposal section of this manual when the Escort M8 Vital Signs Monitor is taken out of service.

For continued operation, always connect the monitor to a wall outlet when a Low Battery alarm indication occurs. Failure to do this can lead to an interruption of monitoring.

The battery may need to be recharged if the Escort M8 Vital Signs Monitor has been powered off for an extended period of time. See the Battery Operation section of this manual for details regarding charging the battery.



Patents and Licensing

This device is covered under one or more of the following U.S. Patents: 5,482,036; 5,490,505; 5,632,272; 5,685,299; 5,758,644; 5,769,785; 6,002,952; 6,036,642; 6,067,462; 6,206,830; 6,157,850; 6,277,081 and international equivalents. U.S.A. and international patents pending.

Possession or purchase of this device does not convey any express or implied license to use the device with replacement parts which would, alone, or in combination with this device, fall within the scope of one or more of the patents relating to this device.

1. Overview

This chapter provides a basic overview of the Escort M8 Vital Signs Monitor user interface and a list of the Escort M8 Vital Signs Monitor's main features.

1.1 Escort M8 Vital Signs Monitor Diagrams

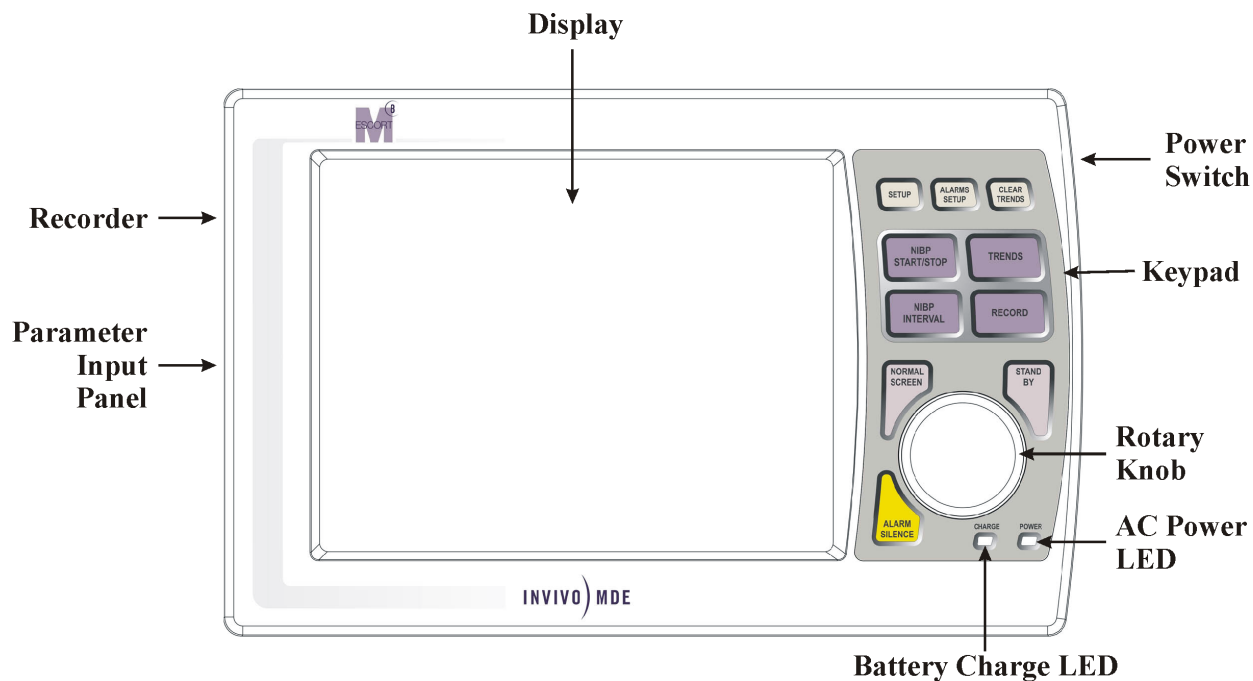

Figure 1-1. Escort M8 Vital Signs Monitor - Front View

Overview

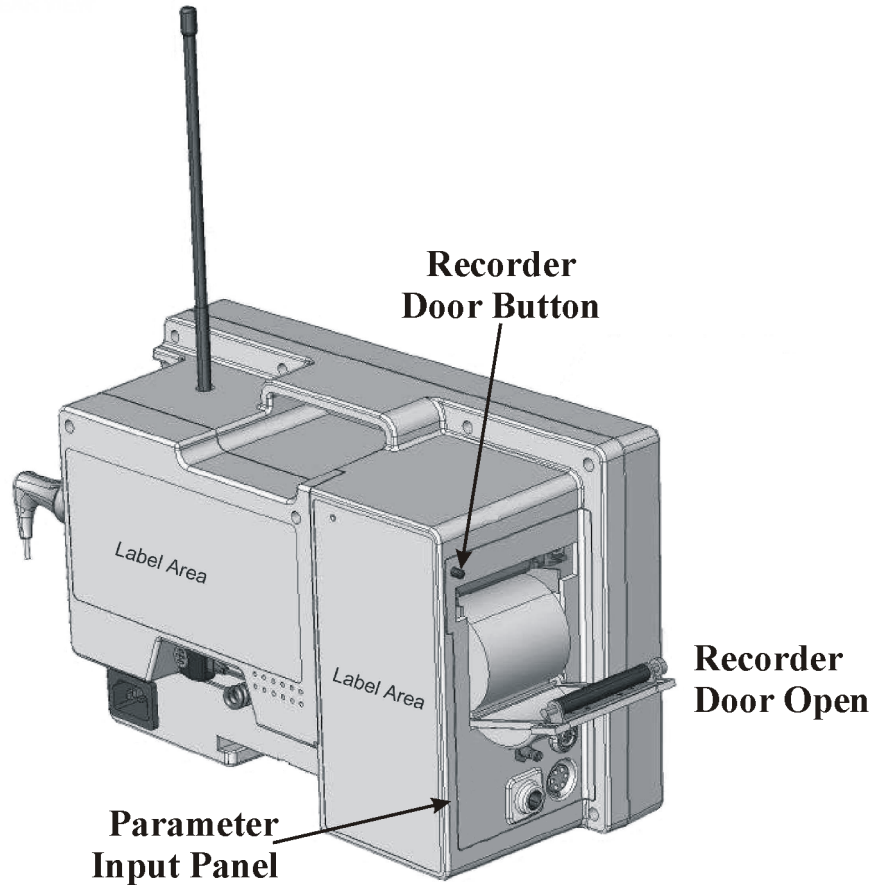

Figure 1-2. Escort M8 Vital Signs Monitor - Left Rear View

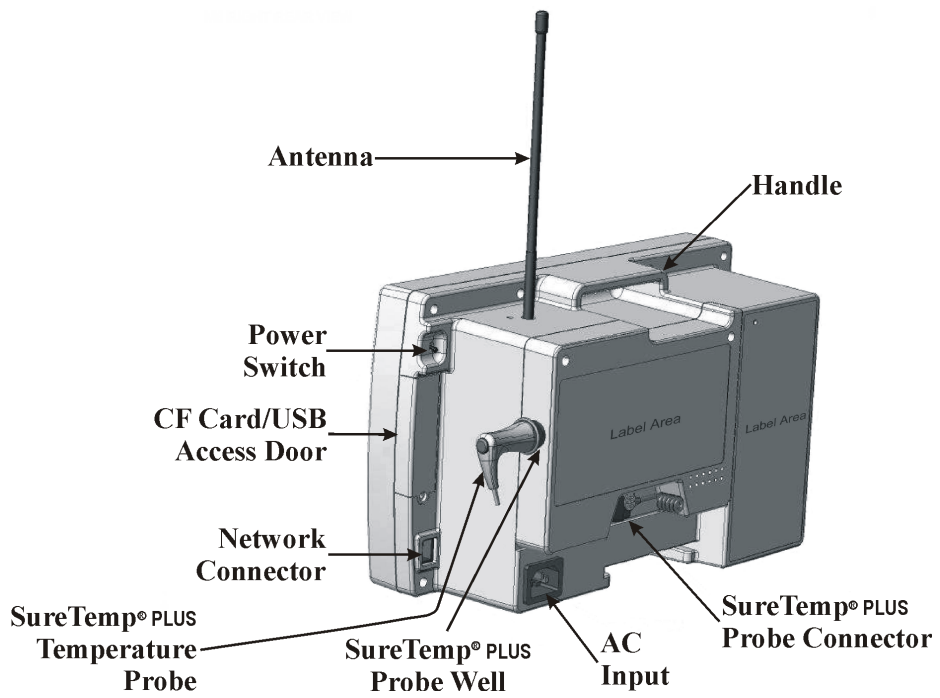

Figure 1-3. Escort M8 Vital Signs Monitor - Right Rear View

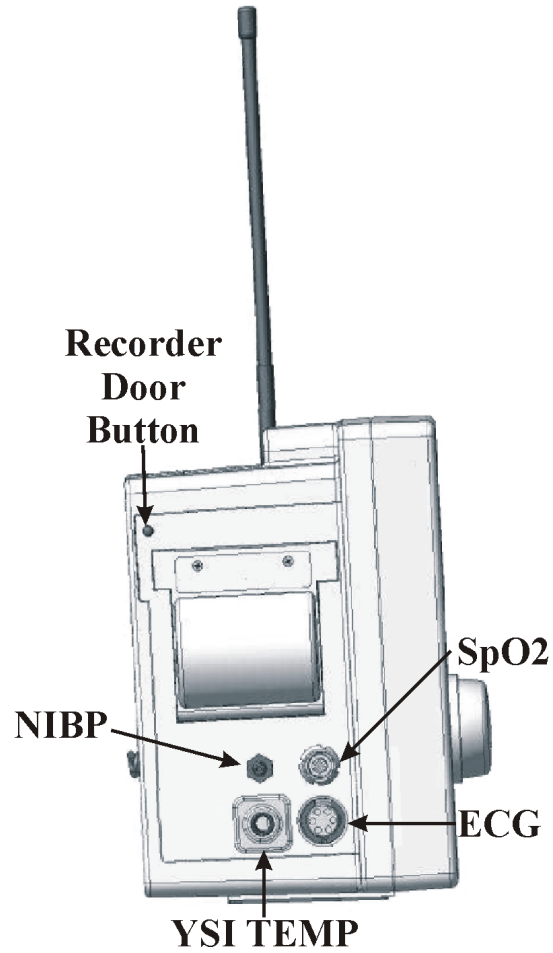

Figure 1-4. Escort M8 Vital Signs Monitor - Left Side View

Overview

1.2 Escort M8 Vital Signs Monitor User Interface

The Escort M8 Vital Signs Monitor user interface makes use of a set of keys and rotary knob on the front panel. The front panel keypad looks like the following diagram:



Figure 1-5. Front Panel Keypad

The Rotary Knob is used to select and rotate through the various monitoring features of this monitor.

The SETUP key is used to bring up the SETUP Menu to allow for the configuration of the different features of this monitor.

The ALARMS SETUP key is used to bring up a menu to allow for the adjustment of the Alarm Limits.

The CLEAR TRENDS key is used to clear the stored trends.

The NIBP START/STOP key is used to either start an NIBP determination or stop one in progress.

The TRENDS key is used to display the stored trends.

The NIBP INTERVAL key is used to set the time interval of the automatic NIBP determination feature.

The RECORD key is used to output a manual strip chart to the recorder or to stop a recording in progress.

The NORMAL SCREEN key is used to return the monitor screen to the regular monitoring display.

The STANDBY key is used to place the monitor into the STANDBY mode of operation.

The ALARM SILENCE key is used to silence active alarms.



Figure 1-6. Example of Escort M8 Vital Signs Monitor Normal Screen

The Normal Screen of the Escort M8 Vital Signs Monitor has four areas: one each for displaying messages, the time, waveforms and parameters.

The message area is at the bottom of the display. Alarm and Technical Condition messages are displayed here. One message is displayed at a time. If multiple messages are active, the messages rotate with each message displayed for approximately three (3) seconds at a time.

The time area is at the bottom right corner of the display. This area displays the current time and battery status.

The waveform area has four (4) channels. Menu selections allow the operator to choose which waveform to display in the lower three (3) channels. The first channel is dedicated to the ECG waveform.

The parameter area is actually in two (2) parts: one to the right of the waveform area and one below it. The parameter area displays the current values of the monitored parameters in a numerical format.

1.3 Main Features of the Escort M8 Vital Signs Monitor

The Escort M8 Vital Signs Monitor connects to a patient and monitors the patient's vital signs. The Escort M8 Vital Signs Monitor contains the hardware and software needed to perform complex data gathering and signal processing tasks that allow it to produce measurements of physiological parameters, such as heart rate, which is labeled on the Escort M8 Vital Signs Monitor as HR. The patient's physiological signals are shown as waveforms on the Escort M8 Vital Signs Monitor display, and the physiological parameters are shown as numbers on the Escort M8 Vital Signs Monitor display. The Escort M8 Vital Signs Monitor can be set up to generate an alarm when a physiological parameter goes beyond a preset limit.

The chapters in the Service Manual explain the details of all the main features of the Escort M8 Vital Signs Monitor. These cover the basic monitoring tasks that may be required when using the Escort M8 Vital Signs Monitor. The main features covered in this Service Manual are as follows:

- Overview.
- Installation and Checkout.
- Configuring the Monitor.
- Battery Operation.
- Functional Verification
- Troubleshooting.

Overview

- Repair.
- Accessories.
- Spare Parts.
- Cleaning.
- Maintenance and Storage.
- Disposal.
- Technical Data.

2. Installation and Checkout

This chapter explains how to install and check out the monitor.

2.1 Preinstallation

Refer to Chapter 13 for a description of facility environmental and power requirements, dimensions, weight and other specifications for the monitor.

2.2 How to Connect the Escort M8 Vital Signs Monitor to Power

WARNING - For safety reasons it is important that the Escort M8 Vital Signs Monitor be powered from an outlet where the ground plug receptacle is connected to earth ground. Do not remove the grounding conductor from the power plug or use electrical power without proper grounding.

To connect the Escort M8 Vital Signs Monitor to power, perform the following procedure:

1. Plug the power cord into a hospital grade AC outlet.
2. Plug the other end of the power cord into the power connector on the back of the Escort M8 Vital Signs Monitor.
3. Observe that the green Charge LED is now illuminated.
4. Flip the power switch on the back side of the Escort M8 Vital Signs Monitor to the ON position.
5. Observe that the green POWER LED is now illuminated and that the monitor screen lights up and then goes through the power up routine.

NOTE - Upon monitor power-on, it may take as long as 30 seconds before the monitor display is visible.

6. The waveforms and parameter values are not displayed until the Escort M8 Vital Signs Monitor is connected to a patient.

To power-down the Escort M8 Vital Signs Monitor, perform the following procedure:

1. Flip the power switch on the back side of the Escort M8 Vital Signs Monitor to the OFF position.
2. Observe that the green POWER LED is no longer illuminated and that the monitor screen goes blank.

NOTE - The monitor should remain connected to the hospital grade AC outlet even when the Escort M8 Vital Signs Monitor is not in use as this allows the battery to be recharged. The battery charge indicator will remain illuminated under these conditions.

Installation and Checkout

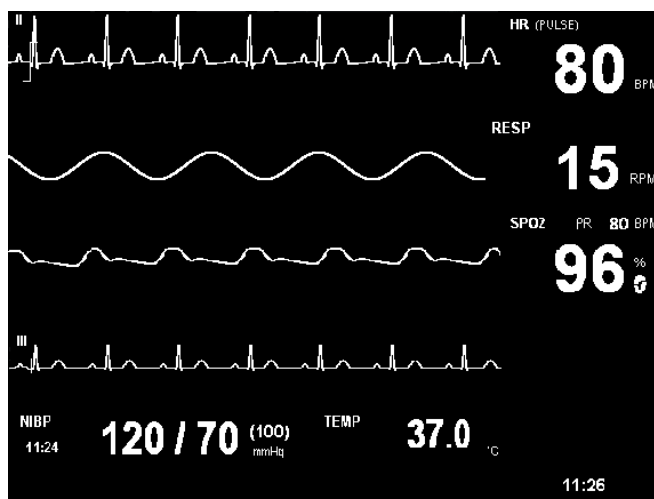

Figure 2-1. Escort M8 Vital Signs Monitor Normal Screen

2.2.1 Operational Checkout Procedure

Before connecting the Escort M8 Vital Signs Monitor to a patient connect the NIBP Hose/Cuff and SpO2 sensor to the monitor then perform the following procedure:

1. Power up the unit and confirm that the startup tones sound before the Normal Screen appears (approximately 10 to 15 seconds after initial power-up).
2. Confirm that the power-on LED is illuminated on the front keypad.
3. Confirm that the display shows the Normal Screen.
4. Press NIBP Start/Stop key and confirm that the pump starts and inflates the cuff.
5. Press NIBP Start/Stop key and confirm that the pump stops.
6. Test the Parameter alarm System as follows:
 - (1) Press the ALARMS SETUP key.
 - (2) Rotate the Rotary Knob until the SPO2 Alarms On option is highlighted then press the knob.
 - (3) Rotate the Rotary Knob until the Yes option is highlighted then press the knob.
 - (4) Rotate the Rotary Knob until the OK option is highlighted then press the knob.
 - (5) Apply the SpO2 sensor to your finger and wait for the SpO2 reading to be displayed.
 - (6) Disconnect the SpO2 sensor from the monitor.
 - (7) After ten (10) seconds, verify that the monitor sounds a low grade Alarm Tone, flashes the SPO2 Icon (the box that contains the SpO2 measurements) and displays the message “SpO2 unplugged.”
 - (8) Press the ALARM SILENCE key.
 - (9) Reconnect the SpO2 sensor to the monitor.
7. (If installed) Press the RECORD key and confirm that the Recorder starts.
8. (If installed) Press the RECORD key and confirm that the Recorder stops.
9. Unplug the power connector from the back of the monitor and confirm that the monitor continues to operate on battery power.

10. Reconnect the power connector to the back of the monitor.

3. Configuring the Monitor

This chapter explains how to configure the monitor.

3.1 System Setup

The Escort M8 Vital Signs Monitor Setup Menu System provides access to operational and parameter settings. The Operational Menus are configured for easy access through the use of a keypad on the monitor front panel. The Parameter Menus are configured, also for easy access through the use of a Parameter Icon system and a Rotary Knob.

Menu options are selected by using the Rotary Knob. To select an option turn the Rotary Knob until the desired option is highlighted, then press the knob to select.

Menus have a two (2) minute timeout feature. If no action is taken for two (2) minutes this menu will automatically close and return the monitor to the normal monitoring mode. To manually return to normal monitoring mode, press the NORMAL SCREEN key.



Figure 3-1. Setup Menu

3.1.1 Setup Menu

To access the Setup Menu, press the SETUP key on the monitor front panel. The Setup options available are Parameters, Waveforms, Recorder, Alarm Suspend, Save/Restore and Biomedical; there is also a Close option that will return the monitor to normal monitoring mode.

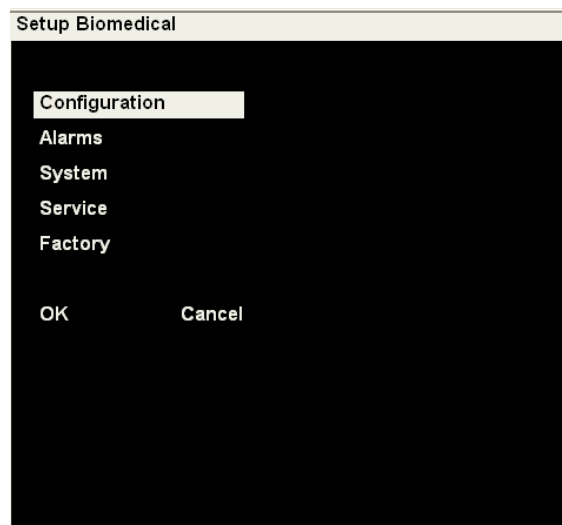

Figure 3-2. Setup Biomedical Menu

3.1.2 Setup Biomedical Menu.

To access the Setup Biomedical Menu, rotate the Rotary Knob until the Biomedical option is highlighted then press the Knob. This menu allows the operator to view the monitor configuration, configure the alarm system parameters, configure the system, set the monitor up for service and perform factory setups.

Configuring the Monitor

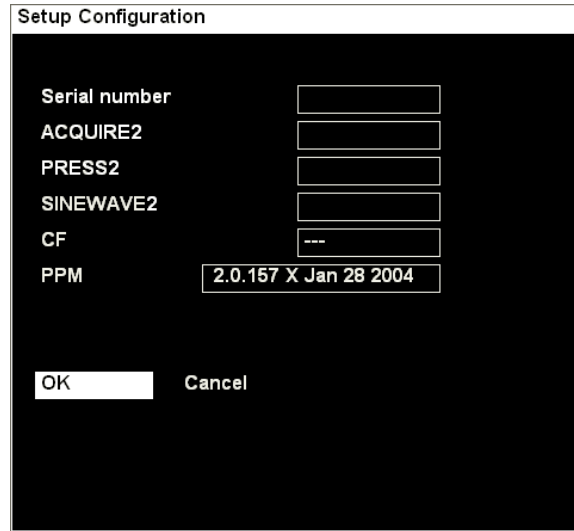

Figure 3-3. Setup Configuration Menu

1. **Setup Configuration Menu.** To view the monitor configuration, rotate the Rotary Knob until the Configuration option is highlighted then press the knob. The Setup Configuration screen will appear which provides the operator with information about the monitor. Rotating the Rotary Knob to highlight either OK or Cancel, then pressing the knob, will return the monitor to normal monitoring mode.

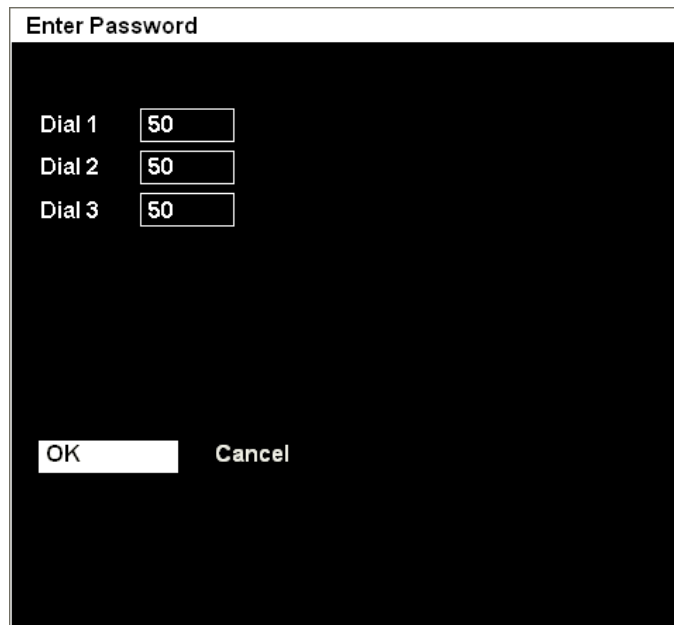

Figure 3-4. Enter Password Menu

2. If **Alarms** or **System** is selected in the Setup Biomedical menu, the Escort M8 Vital Signs Monitor will first bring up the Enter Password Menu. To continue on the the Setup Alarms or Setup System Menu, the correct password must be entered. The password is located at the end of the **Maintenance and Storage** section of this document.

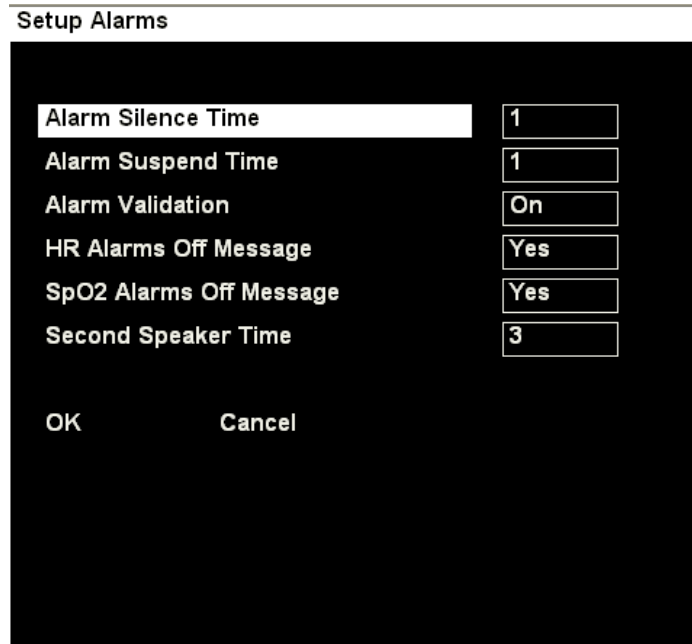

Figure 3-5. Setup Alarm System Menu

3. **Setup Alarm System Menu.** To access the Alarm System Setup Menu, rotate the Rotary Knob until the Alarms option is highlighted then press the knob. This menu provides the operator with options to select the Alarm Silence Time, select the Alarm Suspend Time, turn Alarm Validation On or Off, turn HR Alarms Off Message On or Off, turn the SpO2 Alarms Off Message On or Off and set the Second Speaker Time.

Setting Name	Default Value	Possible Values
Alarm Silence Time	1 minute	1 - 4 minutes
Alarm Suspend Time	1 minute	1 - 4 minutes
Alarm Validation	On	Off, On
HR Alarms Off Message	On	Off, On
SpO2 Alarms Off Message	On	Off, On
Second Speaker Time	2 minutes	0 - 3 minutes

Configuring the Monitor

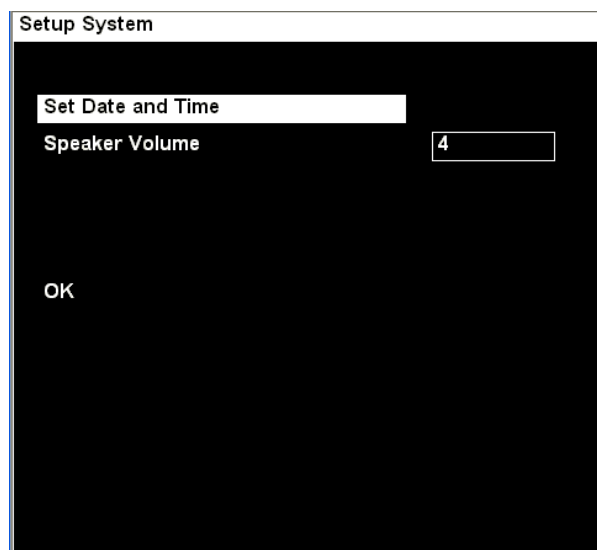

Figure 3-6. Setup System Menu

4. **System.** To access the Setup System Menu, rotate the Rotary Knob until the System option is highlighted then press the knob. This menu provides the operator with the ability to set the Date and Time as well as to adjust the volume of the Speaker.

Setting Name	Default Value	Possible Values
Speaker Volume	4	1 - 10

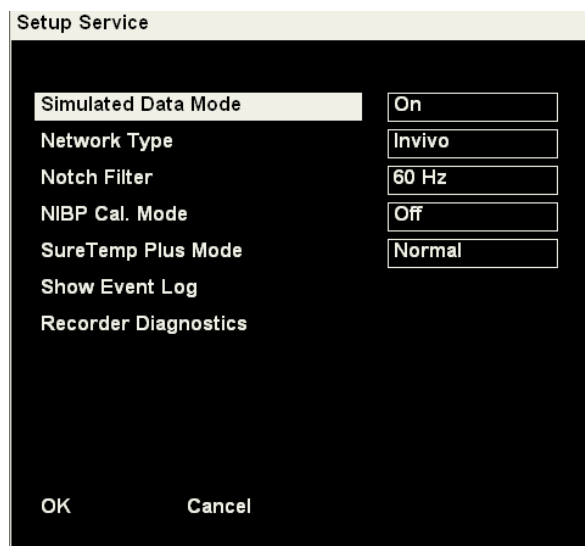

Figure 3-7. Setup Service Menu

5. **Service.** To access the Setup Service Menu, rotate the Rotary Knob until the Service option is highlighted then press the knob and enter the Service Password. This menu provides service related information and is for the use of InvivoMDE qualified service personnel only.

Setting Name	Default Value	Possible Values
Simulated Data Mode	Off	On, Off
Network Type	Invivo	Invivo, ZNET

Configuring the Monitor

Setting Name	Default Value	Possible Values
Notch Filter	60 Hz	Off, 50 Hz, 60 Hz
NIBP Calibration Mode	Off	On, Off
SureTemp® PLUS Mode	Normal	Normal, Monitor

The Simulated Data Mode setting can be used to place the Escort M8 Vital Signs Monitor in a “demo” mode where simulated patient waveforms are displayed. This setting should always remain Off during patient monitoring.

The Notch Filter setting should be set to match the AC mains frequency of the facility (50 or 60 Hz).

The NIBP Cal. Mode setting can be used to place the NIBP algorithm in a calibration mode. In this mode, the valves are closed and the cuff pressure is displayed in 10ths of mmHg. A mercury column can then be used to check the accuracy of the internal NIBP cuff pressure transducer as part of periodic maintenance.

6. **Factory.** To access the Setup Factory Menu, rotate the Rotary Knob until the Factory option is highlighted then press the knob and enter the Service Password. This menu provides access to the Factory setups for the monitor and is for the use of InvivoMDE factory personnel only.

4. Battery Operation

An internal lithium-ion battery allows the Escort M8 Vital Signs Monitor to be disconnected from the wall power and use it for applications where mobility is required.

When the battery is fully charged, it provides for at least 5 hours of normal operation. When the Escort M8 Vital Signs Monitor is operating on battery power, a battery icon appears on the normal screen. The battery icon is designed to give an approximate sense of how much battery life is remaining.

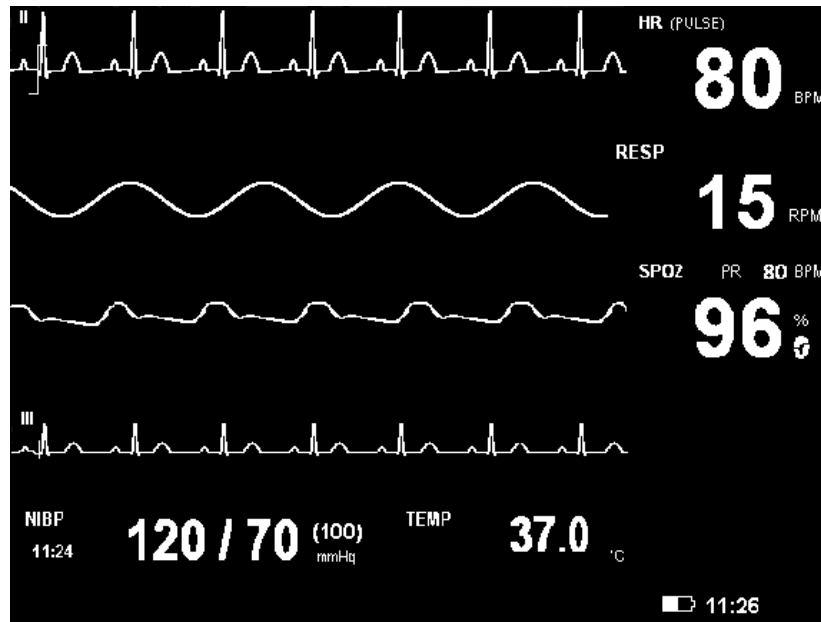

Figure 4-1. Normal Screen Showing Battery Icon

When the battery is running out of charge, the battery icon starts to blink, a Low Battery alarm message is displayed and an alarm tone is annunciated. When this happens, as little as five (5) minutes of battery charge is remaining, and the Escort M8 Vital Signs Monitor should be connected to a wall outlet in order to prevent a loss of patient monitoring.

When the battery power is too low to continue normal operation, the Escort M8 Vital Signs Monitor display will go blank except for the message “Battery Nearly Depleted” and a constant low-grade tone will be generated.

When the Escort M8 Vital Signs Monitor is reconnected to the wall power it will begin recharging. Battery charging occurs regardless of whether the Escort M8 Vital Signs Monitor is powered on. For every hour of battery use, it takes approximately one hour to recharge the battery. A fully depleted battery takes approximately five (5) hours to fully recharge.

The green LED on the front of the Escort M8 Vital Signs Monitor indicates that the battery is being charged. To determine when the battery is full charged, disconnect the battery from the wall power and check the battery icon on the Escort M8 Vital Signs Monitor home screen.

The toggle switch on the back of the Escort M8 Vital Signs Monitor allows you to turn the Escort M8 Vital Signs Monitor on and off.

See the Maintenance section for details on how to replace the battery.

WARNING - Consult the safety instructions at the front of this manual regarding the proper use and disposal of the battery.

5. Functional Verification

This chapter discusses the recommended functional verification checks for the 3800 Vital Signs Monitor and its accessories.

The following is a list of test equipment that you will need to perform the functional verification:

Test Equipment	Description
Patient ECG/Respiration Simulator	Bio-Tek Instruments LH-3 (or equivalent)
Patient SpO2 Simulator	Bio-Tek Instruments Index-2 (or equivalent)
Patient NBP Simulator (calibrated)	Bio-Tek Instruments BP-Pump (or equivalent)

The functional verification procedures are listed below:

Monitor Function	Procedure
Mechanical Integrity	Check for cracks, abrasive edges and other signs of damage.
Front Panel Keys/Rotary Knob	<ul style="list-style-type: none"> • Verify turning the rotary knob clockwise and counter-clockwise allows the monitor to scroll to the right and left. Pushing the knob causes selection. • Setup key: verify access to Setup menu. • Alarms Setup key: verify access to the Setup Alarms menu. • Clear Trends key: verify access to the Clear Trends menu. • NIBP START/STOP key: verify NIBP measurements start and stop. • Trends key: verify access to the Trends menu. • NIBP Interval key: verify access to the Setup NIBP Interval menu. • Record key: verify recording strips start and stop. • Normal Screen key: verify return to “Normal Screen” from any popup menu. • Standby key: verify Standby mode. • Alarm Silence key: verify silencing of alarm.
Power LED	Verify that the green power LED is illuminated on the 3800 Vital Signs Monitor.
Battery Charging LED	Verify that the green charging LED is illuminated on the 3800 Vital Signs Monitor when plugged into mains power.
Speaker	Power-cycle the 3800 Vital Signs Monitor and verify that the power-up speaker test tones are generated. (One low-pitched tone, followed by one medium-pitched tone, followed by two high-pitched tones.)
ECG/Respiration	<ul style="list-style-type: none"> • Connect ECG leads to Patient Simulator. • Verify proper heart rate at 30 and 300 bpm (± 2 bpm or ± 1 %). • Verify proper respiration rate at 15 and 120 bpm (± 3 bpm).

Functional Verification

Monitor Function	Procedure
SpO2	<ul style="list-style-type: none"> • Connect to Patient Simulator (select appropriate sensor type). • Verify proper SpO2 value at 84% and 96% (± 2 O2%). • Verify proper PR value at 30 and 240 bpm (± 5 %).
NBP	<ul style="list-style-type: none"> • Connect Patient Simulator and take an NBP measurement. • Verify proper NBP value at 120/80 (± 5 bpm).
YSI Temperature	None (self-checking).
Recorder	Verify strip chart recording of waveform data followed by a parameter snapshot.

To place the 3800 Vital Signs Monitor back in service after functional verification has been performed, connect the 3800 Vital Signs Monitor to a wall outlet, ensuring that cables do not present a tripping hazard.

6. Troubleshooting

This chapter is meant to help you solve problems that you may encounter while operating the 3800 Vital Signs Monitor.

The Operations Manual (InvivoMDE P/N 9565) also contains troubleshooting tips in each of the physiological monitoring chapters. These should be consulted for general monitoring problems that seem patient-related.

If you are still experiencing a problem and none of these steps seem to help, please contact InvivoMDE Technical Service:

US: (888) 221-1593

Int'l: (407) 275-3220

Troubleshooting the 3800 Vital Signs Monitor consists of the following basic steps:

1. Determine whether the problem is external (i.e., a defective cable) or internal to the monitor.
2. If external, replace the defective cable and then functionally verify proper operation before returning the monitor to service.
3. If internal, replace the defective part/sub-assembly where appropriate and functionally verify all monitoring functions before returning the monitor to service.

6.1 Power-up Malfunctions

6.1.1 Display Is Blank At Power-Up (No Power LED Illuminated)

Description: Upon power-up, the display is blank, even after several minutes. The green Power LED is not illuminated in the front key panel. Pressing the NBP Start/Stop key doesn't cause the NBP pump to start.

Possible Cause(s):

1. No power at facility wall outlet.
2. The monitor's power switch is set to Off.
3. Internal system error.

Troubleshooting Action(s):

1. Check facility wall outlet power with a voltmeter or known good piece of equipment.
2. Confirm that the green Power LED is illuminated when the monitor is plugged into the wall outlet.
3. Confirm that the monitor's power switch is in the On position. The switch is located on the rear of the monitor.

6.1.2 Display Is Blank At Power-Up (with Power LED Illuminated)

Description: Upon power-up, the display is blank, even after several minutes. The green Power LED is illuminated in the front key panel. Pressing NBP Start/Stop causes the NBP pump to start (though not necessarily).

Possible Cause(s):

1. Battery needs charging.
2. Battery is non-functional.
3. The internal display cable has become unseated.

Troubleshooting

Troubleshooting Action(s):

1. Connect the monitor to mains AC power. Power-cycle the monitor. If the monitor now starts, then the battery needs to be recharged. Leave the monitor connected to mains AC power for a minimum of 4 hours. If the monitor does not start, then continue on.
2. Disassemble the monitor according to the monitor disassembly procedure, up to the point where the battery pack is removed from the rear case assembly.
3. Connect the power cable into the back of the monitor.
4. If the monitor now runs through its complete power-up sequence and displays the “Normal” screen, then the battery needs to be replaced. If the monitor still exhibits the problem, continue on.
5. Continue to disassemble the monitor according to the monitor disassembly procedure, up to the point where the monitor rear case assembly is unscrewed from the monitor front bezel assembly (but the internal connectors are still attached).
6. Ensure that the 32-pin ribbon display cable is firmly attached to the main board and LCD display in the monitor front bezel assembly.
7. At this point, connect the power cable into the back of the monitor. (The battery pack need not be reattached.)
8. Confirm that the monitor runs through its complete power-up sequence and displays the “Normal” screen. If so, disconnect the power cable from the monitor and re-assemble the monitor according to the monitor reassembly procedure.
9. Otherwise, the display may need to be replaced. See the replacing the display section of the Repair chapter for details.

6.1.3 Monitor Only Displays the Power-Up (“Invivo)MDE M8”) Banner

Description: Upon power-up, the power-up banner is displayed and a single beep tone is generated. At this point, the power-up sequence stalls and the main monitoring “Normal” screen is never displayed.

Possible Cause(s):

1. Internal Compact Flash card or interface board has become unseated.
2. Bad Compact Flash card.

Troubleshooting Action(s):

1. Disassemble the monitor according to the monitor disassembly procedure.
2. In the middle of the Master Processor (Bitsy board) is an adapter board that contains a Compact Flash card. Ensure that the card is firmly seated in the adapter board. Ensure that the adapter board is fully seated in the Bitsy board.
3. Reattach the keypad, display speaker and Power LED connectors to the main board.
4. At this point, connect the power cable into the back of the monitor. The battery pack need not be reattached.
5. Confirm that the monitor runs through its complete power-up sequence and displays the “Normal” screen. If this doesn’t occur, then the Compact Flash card may need to be replaced. This can be obtained as a replacement part (see Spare Parts chapter).
6. If the power-up sequence now works, disconnect the power cable from the monitor and re-assemble the monitor according to the monitor reassembly procedure.

6.1.4 Power-Up Banner Is Followed by A Blank Screen

Description: Upon power-up, the “Invivo)MDE M8” banner is displayed and a double beep tone is generated. At this point, the banner is replaced by a blank screen or by a screen with garbled blocks of symbols.

Possible Cause(s):

1. On earlier units, this can occur if the monitor was powered-off before the previous power-up sequence was allowed to complete.
2. Internal real-time clock (coin cell) battery is depleted.

Troubleshooting Action(s):

1. Power-down and then power-up the monitor. If the problem was an incomplete power-up sequence, then this problem will correct itself.
2. If the problem still occurs, then the coin cell battery may need to be recharged. Leave the monitor powered-on and connected to mains AC power for a minimum of 1 hour. Then power-cycle the monitor.

6.1.5 Monitor Does Not Run on Battery Power

Description: The monitor runs on mains AC power but will not run on battery power.

Possible Cause(s):

1. Battery needs charging.
2. Battery no longer holds a charge.

Troubleshooting Action(s):

1. Connect the monitor to mains AC power in order to recharge the battery. The monitor may be powered on or off during this process.
2. Verify that the green Power LED and the green Battery LED are illuminated on the front of the monitor. If the Power LED is not illuminated, then either the power supply needs to be replaced or there is no mains AC power at the wall outlet.
3. If the Battery LED is not illuminated, then the battery charger board needs to be replaced. This can be obtained as a replacement part (see Spare Parts chapter). Otherwise, continue on.
4. After 4 hours, disconnect the monitor from the wall outlet and power it On. If the monitor still does not power up, then the battery needs to be replaced. See the battery replacement section of the Maintenance and Storage chapter for instructions.

6.2 Physiological Monitoring Malfunctions

6.2.1 Monitor Won't Display an ECG or Respiration Signal

Description: There is no ECG (or respiration) signal on the display when the lead wires are connected to the patient.

Possible Cause(s):

1. The monitor is not configured to display the desired waveform.
2. The electrodes have dried out.
3. Broken lead wire.
4. Inoperable ECG or respiration circuit.

Troubleshooting

Troubleshooting Action(s):

1. Via the Setup Waveforms menu, ensure that the desired waveform is selected for display.

NOTE - With a 3-wire ECG cable, only ECG Lead II is available. Respiration is available across Lead II on both the 3- and 5-wire cables.

2. Replace the electrodes (see M8 Operations Manual for instructions).
3. Try a different ECG lead set to see if there is an internal lead wire break. If so, replace the lead set.
4. Power-cycle the monitor. If the problem persists, contact InvivoMDE Technical Service.

6.2.2 Monitor Displays Constant ECG Pacer Annotations

Description: The monitor is displaying nearly continual ECG pacer annotations at the top of the waveform channel. Patient may or may not have a pacemaker.

Probable Cause(s):

1. Electrodes have dried out.
2. Inoperable ECG circuit.

Troubleshooting Action(s):

1. Replace the electrodes (see M8 Operations Manual for instructions).
2. Power-cycle the monitor. If the problem persists, contact InvivoMDE Technical Service.

6.2.3 Monitor Displays an “SPO2 Replace Sensor” Message

Description: The monitor displays an “SpO2 Replace Sensor” message when the probe is attached.

Probable Cause(s):

1. Faulty sensor.
2. Faulty sensor adapter cable.

Troubleshooting Action(s):

1. Connect a known good sensor and adapter cable to the monitor.

6.2.4 Monitor Displays a “Temp Needs Service” Message

Description: The monitor displays a “Temp Needs Service” message.

Probable Cause(s):

1. One of the reference resistors on the main board is out of tolerance.

Troubleshooting Action(s):

1. Power-cycle the monitor.
2. If the problem persists, then the main board needs to be replaced. This board can be obtained as a replacement part (see Spare Parts chapter).

6.2.5 Monitor Displays an “NBP Needs Service” Message

Description: The monitor displays an “NBP Needs Service” message at either startup or during a measurement. An NBP measurement is not started when the NBP Start/Stop key is pressed.

Probable Cause(s):

1. Overpressure test failed at startup.
2. Internal communication problem between the master processor and NBP hardware controller.
3. Cuff pressure transducer problem.
4. Pressure not releasing from cuff for more than 2 1/2 minutes.
5. Pump not responding.
6. Internal pneumatic tubing has a leak or has become disconnected.
7. Internal software logic error.

Troubleshooting Action(s):

1. Power-cycle the monitor. If the “NBP Needs Service” message occurs during the startup tests (i.e., during the first 60 seconds), then contact InvivoMDE Technical Service for instructions.
2. If the “NBP Needs Service” and “NBP Zeroing” messages are no longer displayed after powerup, then the startup tests have passed. Continue on.
3. If the “NBP Needs Service” message occurs when an NBP measurement is started, then listen when the NBP Start/Stop key is pressed. If the valves can be heard to close (a “clicking” sound) but the pump doesn’t start running, then the pump may be bad or the control line to the pump has a break. Contact InvivoMDE Technical Service for instructions.
4. If the pump does start running but shuts off after 2 seconds (followed by the “NBP Needs Service” message), then the internal pneumatics tubing may be disconnected. Follow the monitor disassembly procedure to gain access to the master processor (bitsy board). The white pneumatic tubing should connect to two valves, the pump (on the lower of the two ports), the two black transducers on the main board below the master processor, and the external NBP fitting. Check these fittings and reassemble the monitor according to the monitor reassembly procedure.
5. If the problem persists, then one of the transducers may be faulty. Contact InvivoMDE Technical Service for instructions.

6.3 Non-Physiological Monitoring Malfunctions

6.3.1 Optional Recorder Not Working

Description: Paper will not feed out of the recorder.

Possible Cause(s):

1. Paper is bound up in the recorder assembly.
2. Recorder is out of paper.
3. No power to the recorder.

Troubleshooting Action(s):

1. Check M8 Alarm Message for possible recorder message.
2. Open recorder door and check to see if paper is jammed.
3. Open recorder door and check to see if paper is loaded into the recorder.

(If recorder needs to be replaced, refer back to monitor disassembly instructions.)

Troubleshooting

6.3.2 Missing Rows or Sections of Display Pixels

Description: The display is missing entire rows or sections of pixels. Menus are still displayed in response to key presses.

Possible Cause(s):

1. The display board is faulty.

Troubleshooting Action(s):

1. Power-cycle the monitor.
2. If the problem persists, then the display board needs to be replaced. See replacing the display section of the Repair chapter for details.

6.3.3 Other Technical Messages

Description: The monitor displays one of the following messages:

- PPM overheating
- PPM disk space low
- PPM CPU overloaded
- Supply voltage too low
- Supply voltage too high

Possible Cause(s):

1. PPM Overheating: internal monitor temperature too high.
2. PPM Overheating: communication problem with the main board.
3. PPM disk space low: Flash Card file system is full.
4. PPM CPU overloaded: internal logic error.
5. Supply voltage too low/high: problem with main board.

Troubleshooting Action(s):

1. Power-cycle the monitor.
2. If the “Supply Voltage too low” problem persists, there may be a problem with the connector between the master processor (bitsy board) and the main board. Disassemble the monitor according to the monitor disassembly procedure. Confirm that master processor is firmly seated into the main board below it. Reassemble the monitor according to the monitor reassembly procedure and power-cycle the monitor.
3. If any of these problems persist, take the monitor out of service and contact InvivoMDE Technical Support for instructions. The main board may need to be replaced in some cases.

6.4 Reducing EMI

The 3800 Vital Signs Monitor complies with regulatory standards regarding electromagnetic compatibility (IEC 60601-1-2). The following is a list of actions that should be taken to reduce problems that are caused by electromagnetic interference (EMI):

1. Only use accessories that are listed in chapter 8 of this manual
2. Ensure that other products in the area comply to accepted emissions standards (EN 55011).
3. Maximize the distance between electromedical devices.
4. Strictly limit the use of portable radio-frequency sources (e.g., cellular phones and radio transmitters).

5. Maintain good cable management. Try not to route cables over electrical equipment.

7. Repair

This chapter describes the procedures for disassembling and re-assembling the 3800 Vital Signs Monitor.

WARNING - Consult the safety instructions at the front of this manual regarding the proper servicing of this monitor.

WARNING - SHOCK HAZARD. The 3800 Vital Signs Monitor's display board utilizes high voltages. Use caution when servicing this component.

The following is a list of tools and test equipment that you will need:

Tools & Test Equipment	Description
Screwdriver	#2 Phillips Head
Torque Limiting Scscrewdriver	#2 Phillips Head

7.1 External Chassis Components

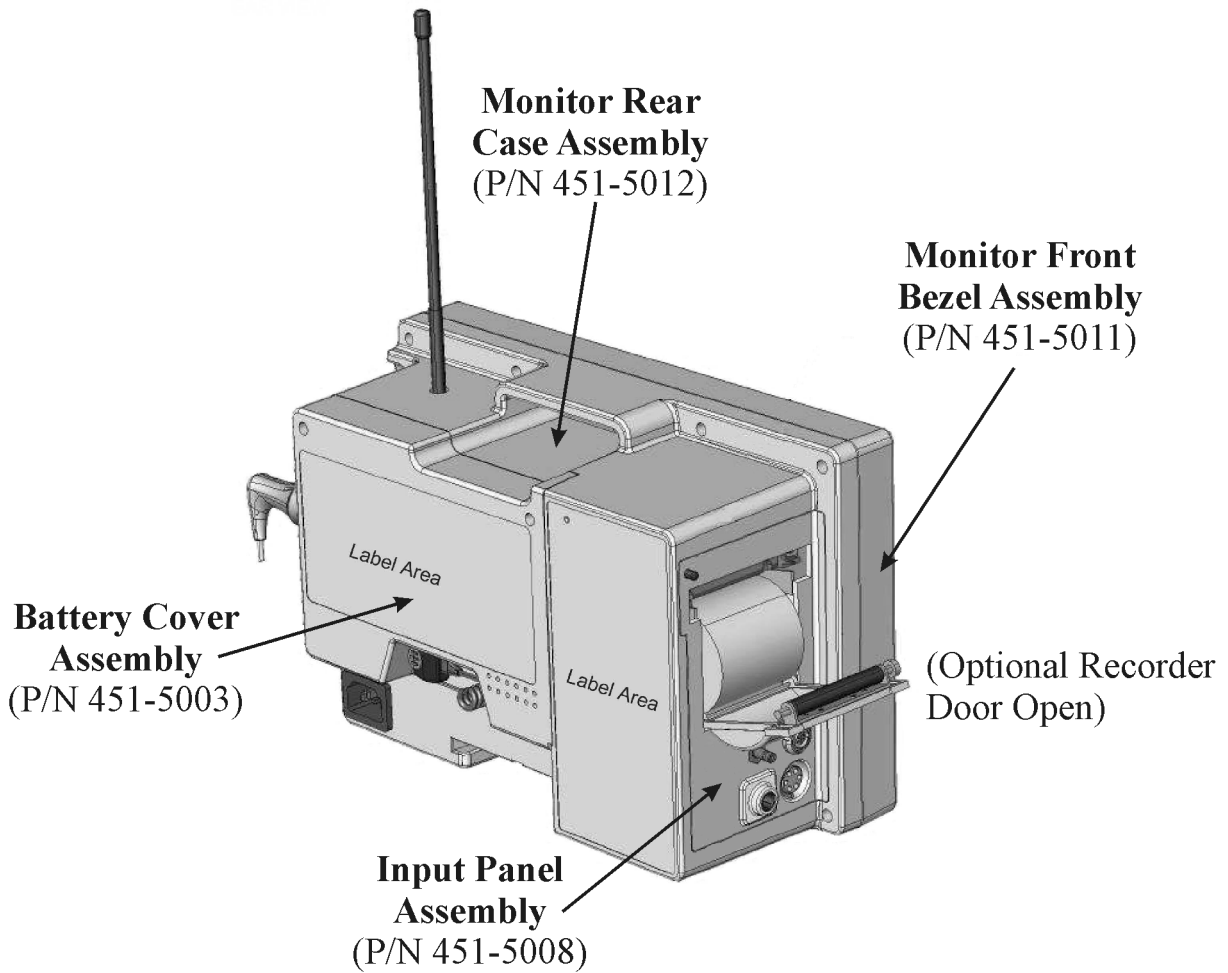

Figure 7-1. External Chassis Components

7.2 Functional Block Diagram

The following is a functional block diagram of the 3800 Vital Signs Monitor:

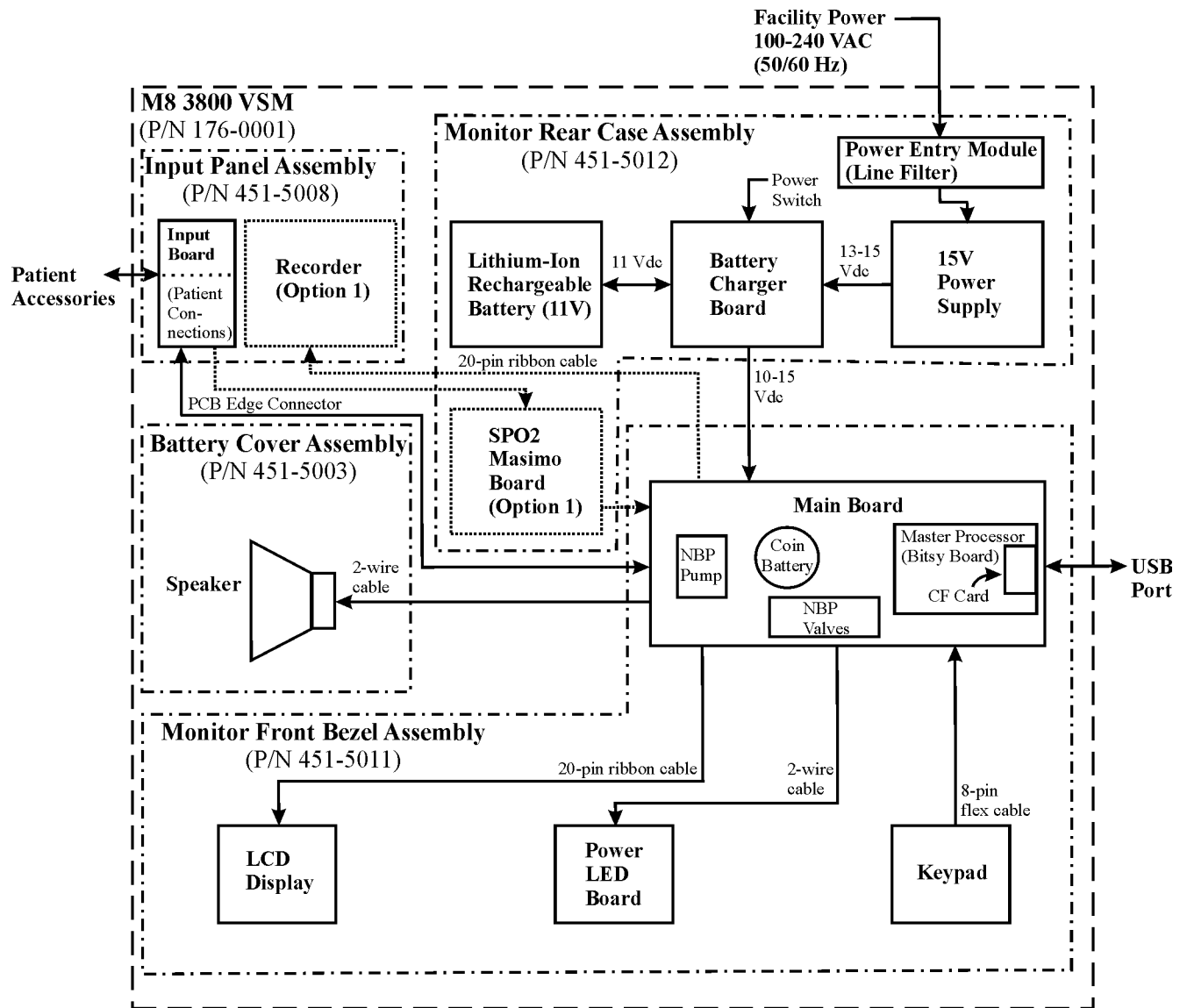

Figure 7-2. M8 Overall Functional Block Diagram

7.3 Cable Interconnection/Wiring Diagram

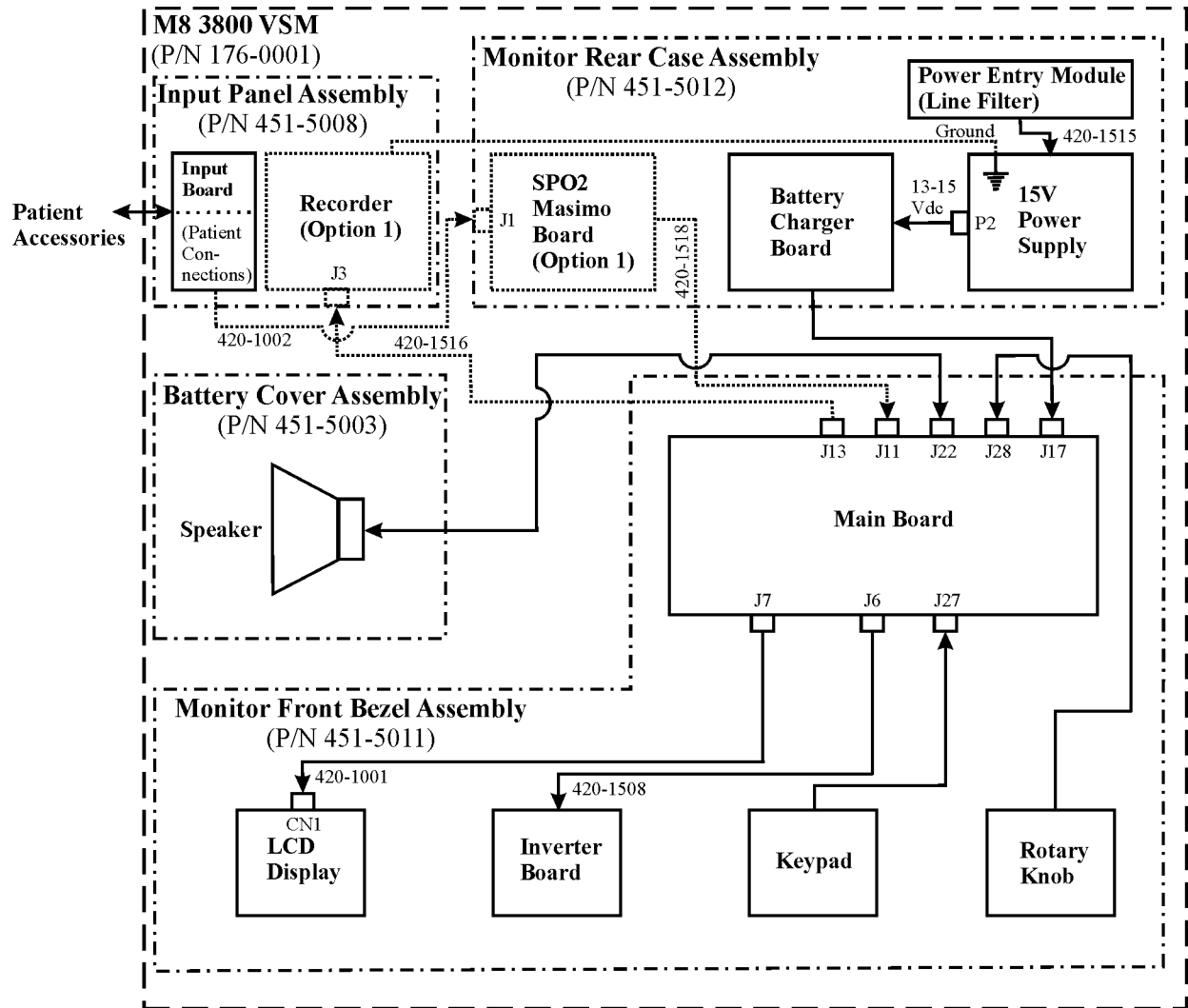

Figure 7-3. M8 Cable Interconnection/Wiring Diagram

7.4 Major Assembly Views

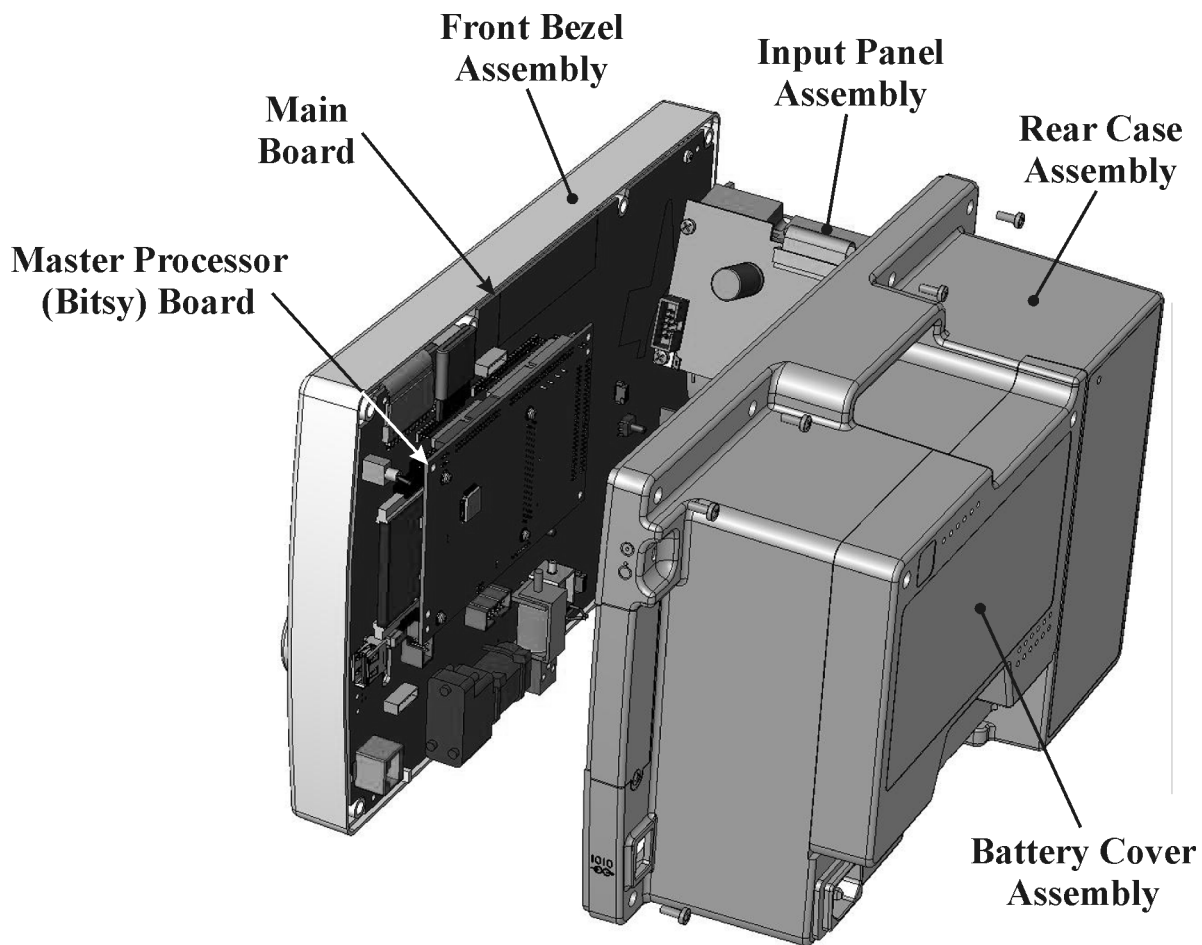

Figure 7-4. Monitor Major Assembly View

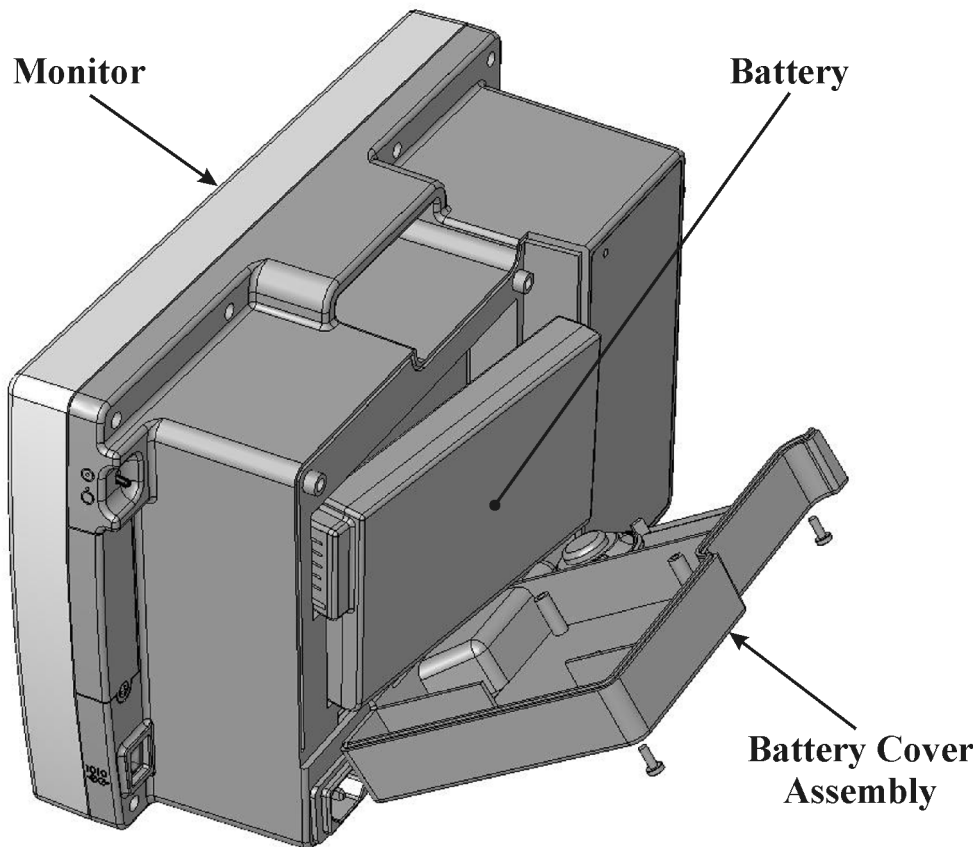

Figure 7-5. Battery Cover Major Assembly View

7.4.1 Assembly/Subassembly Views

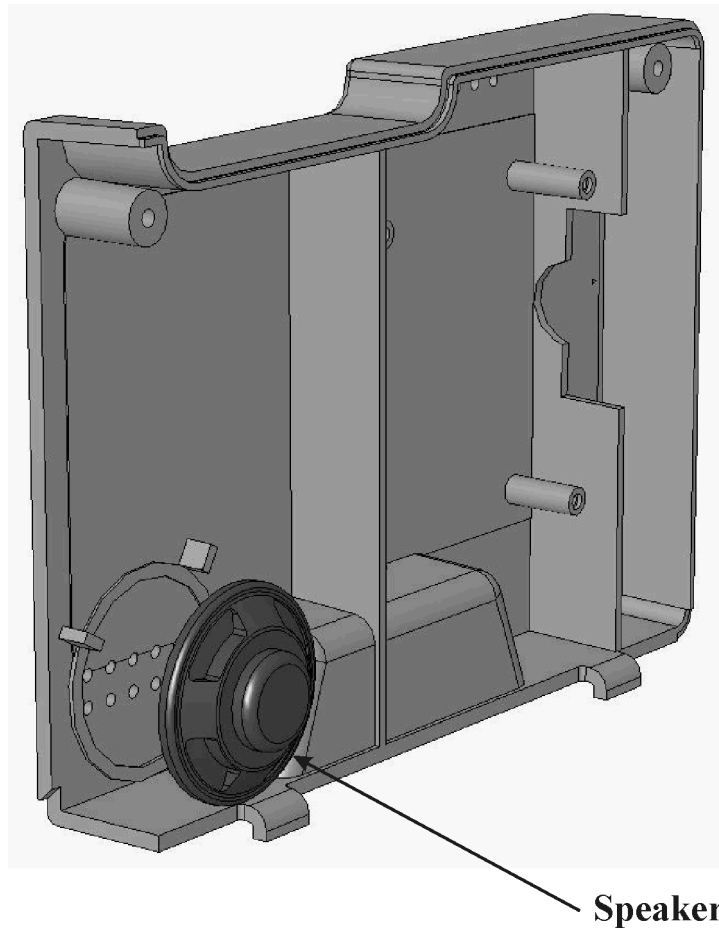

Figure 7-6. Battery Cover Assembly View

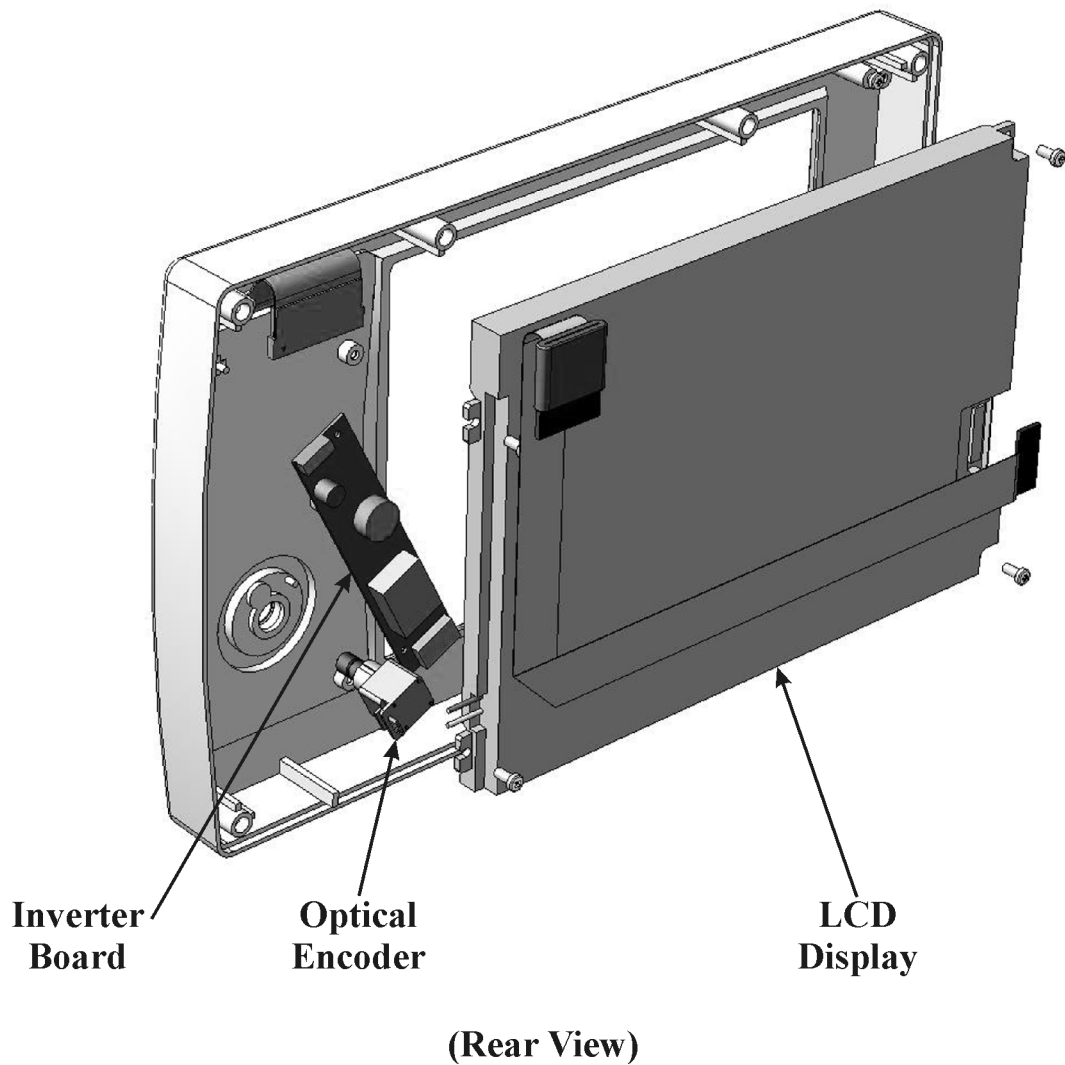

Figure 7-7. Monitor Front Bezel Assembly View A (Rear)

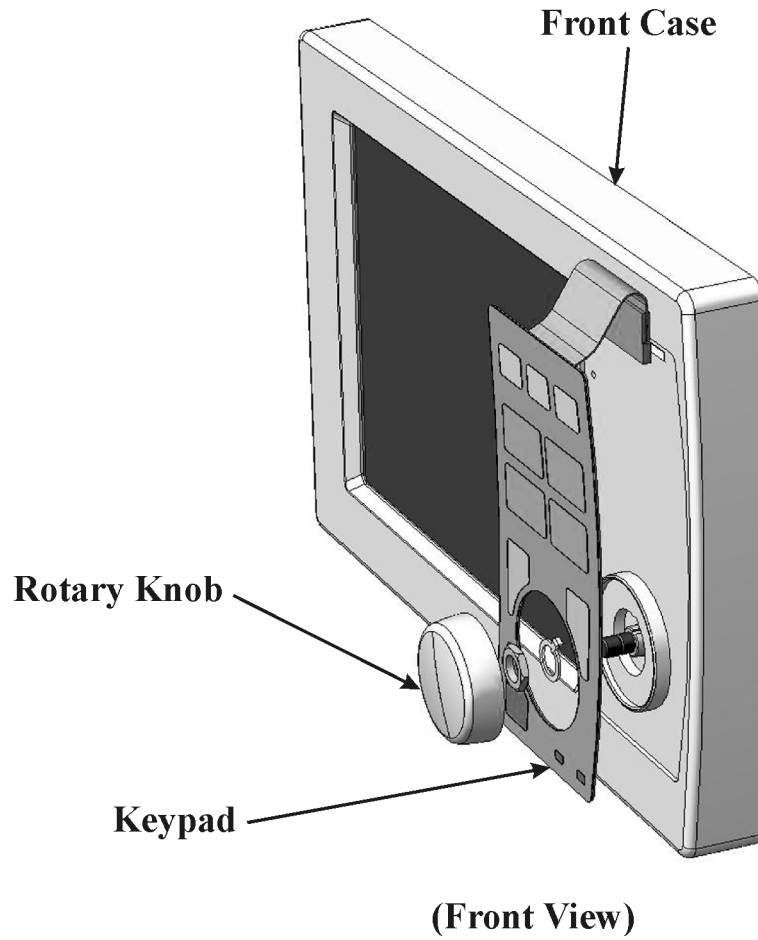

Figure 7-8. Monitor Front Bezel Assembly View B (Front)

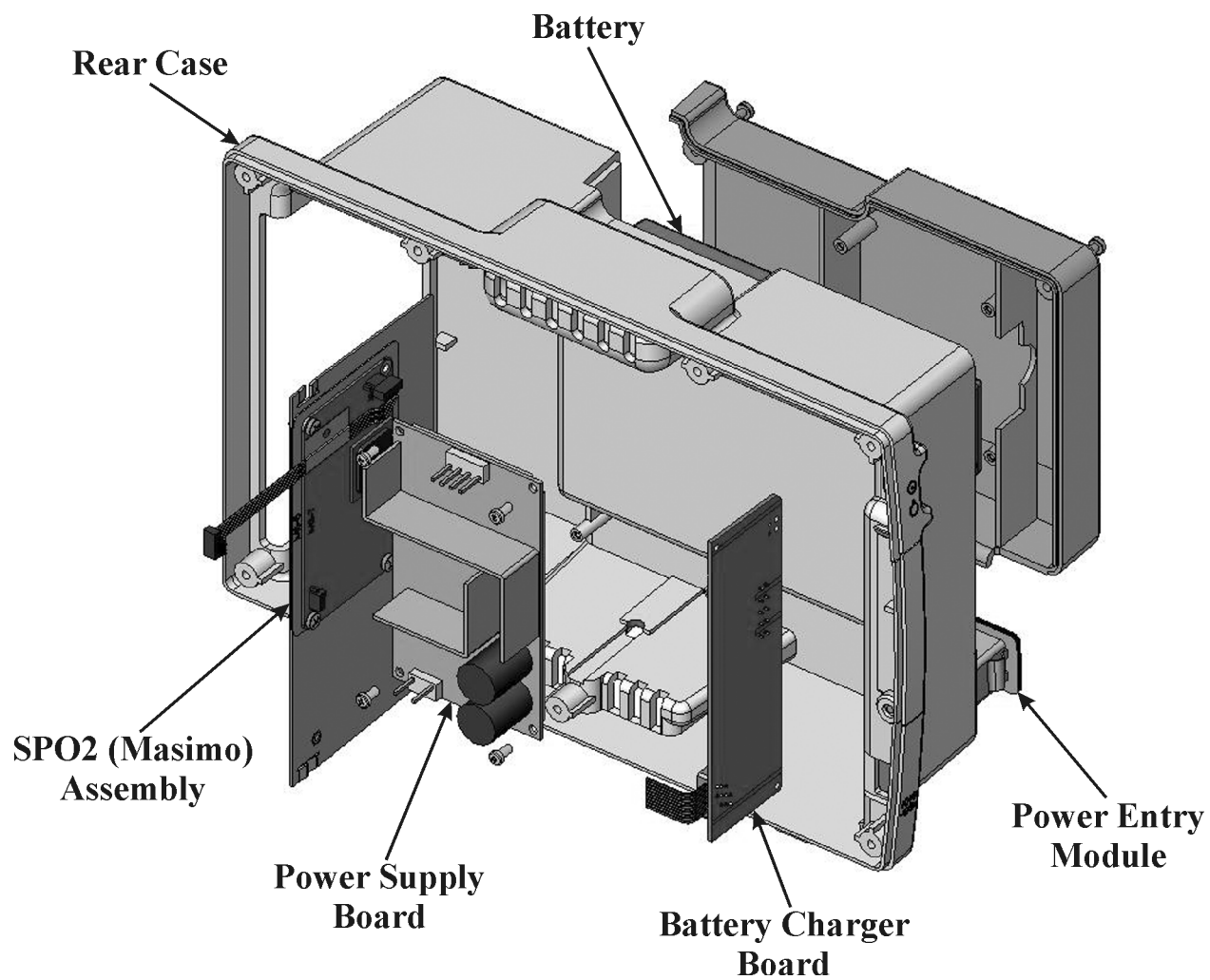

Figure 7-9. Monitor Rear Case Assembly View

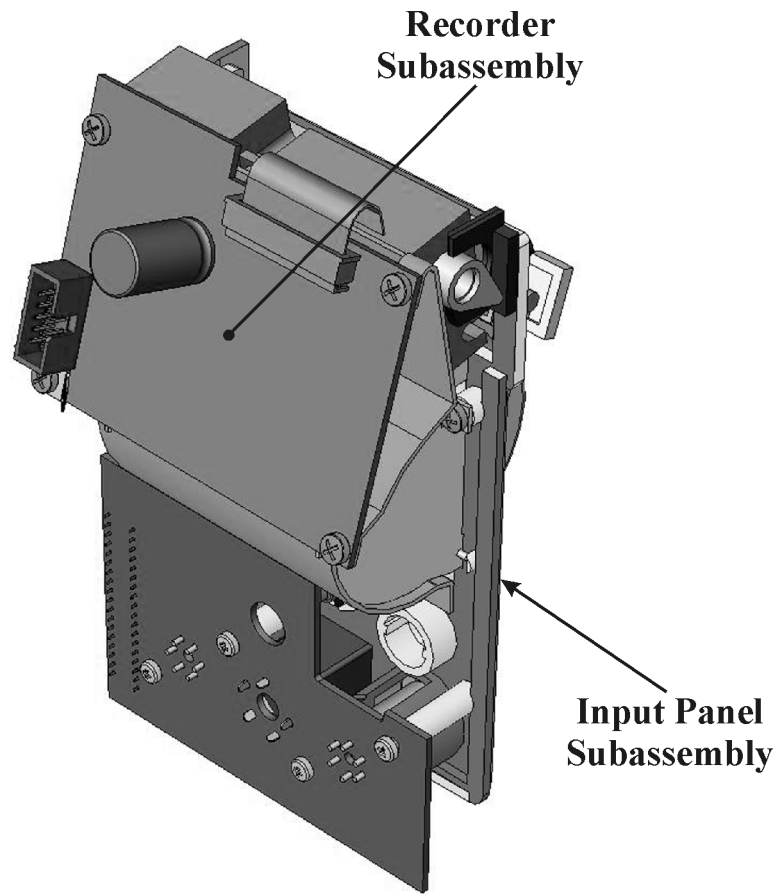

Figure 7-10. Input Panel Assembly View

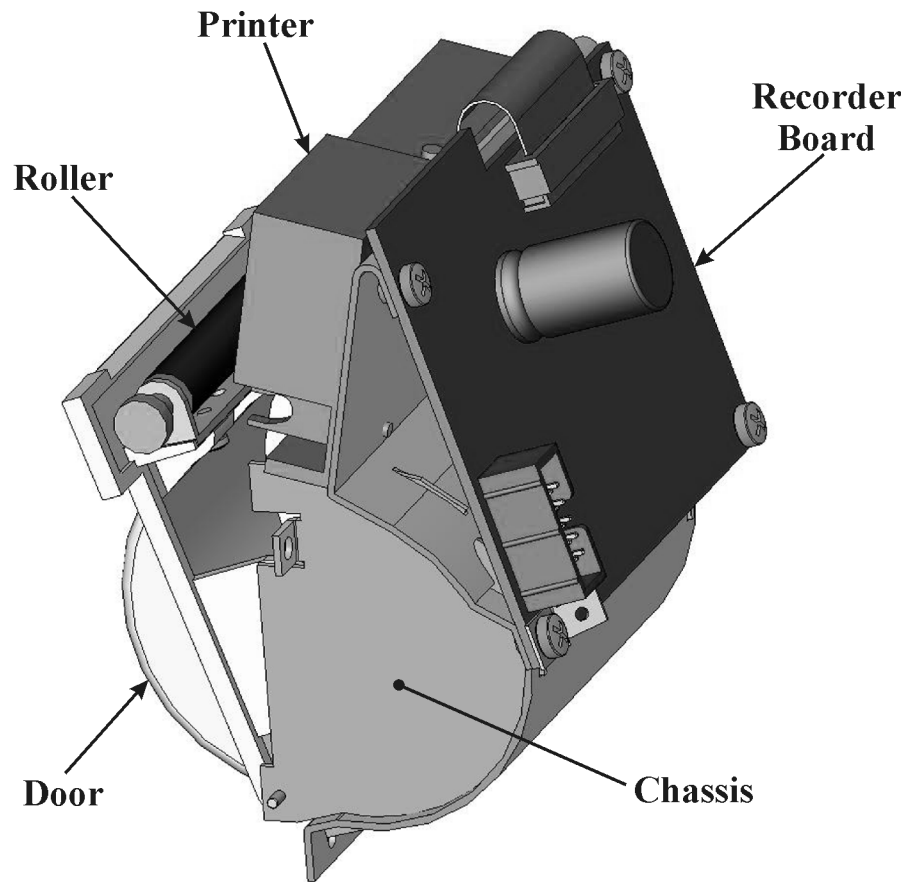

Figure 7-11. Recorder Subassembly View

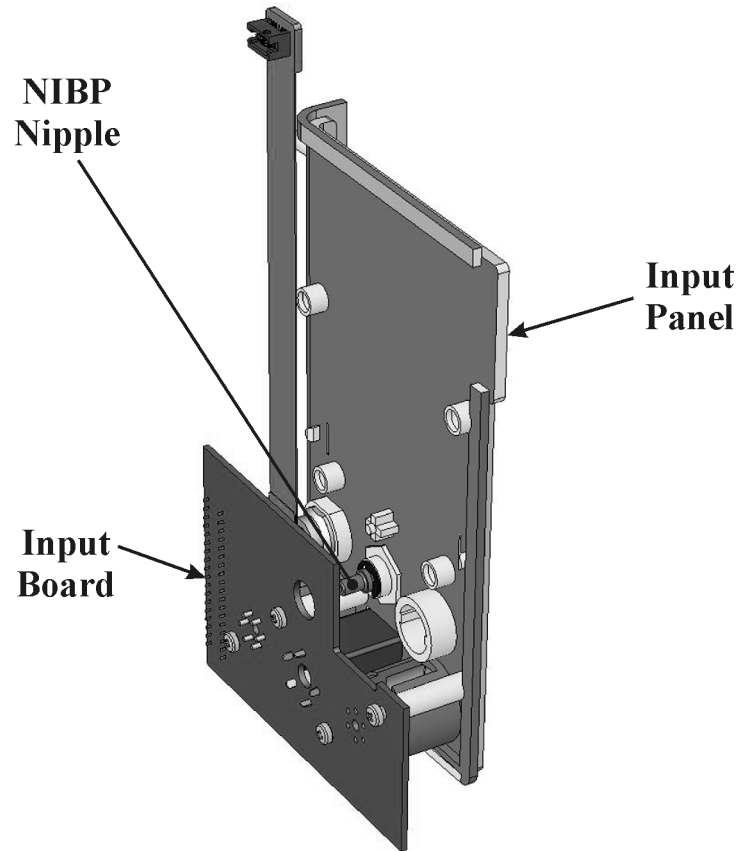

Figure 7-12. Input Panel Subassembly View

7.5 Monitor Disassembly Procedure

1. Disconnect the power cord from the monitor.
2. Place the monitor face down on a padded surface.
3. Remove the battery cover assembly (2 screws).
4. Remove the battery (it lifts out).
5. Detach the monitor rear case assembly from the monitor front bezel assembly (7 screws).
6. Turn the monitor upright so that the display is facing towards you. Carefully separate the front bezel from the rear case assembly.
7. Disconnect the 2-wire speaker connector from the main board at J22.
8. Disconnect the battery charger connector from the main board at J17.
9. Disconnect the ground connection from the recorder board.
10. Disconnect the SPO2 Masimo cable from the main board at J11.
11. Disconnect the Masimo input cable from the SPO2 Masimo board at J1.
12. Detach the front bezel assembly from the monitor rear case assembly.

7.6 Monitor Reassembly Procedure

The monitor can be reassembled by following the disassembly steps in reverse order as a guide.

Remember to functionally verify all monitoring functions before returning the monitor to service. See chapter 5 for details.

A leakage current and di-electric withstand test should be performed if the monitor was disassembled (see chapter 11 for details).

7.7 Replacing the Display

Before getting started, please refer to the figure that shows the monitor front bezel assembly view, located earlier in this chapter.

1. Obtain a replacement LCD display (see Spare Parts chapter).
2. Disassemble the monitor according to the Monitor Disassembly Procedure. This should be done in a static- and dust-free environment in order to maintain cleanliness of the display lens.
3. Remove the damaged display from the monitor front bezel assembly, being careful not to scratch the lens that is mounted in front of the display.
4. Install the new display. These screws should be backed-off until they line up with the already-formed threads, in order to avoid stripping the threads. They should be tightened to 3-4 inch-pounds (0.34-0.45 newton-meters).

7.8 Replacing the Optional Recorder Assembly

1. After monitor disassembly is performed, remove the main board.
2. Disconnect the recorder cable from the recorder board at J3.
3. Disconnect the Masimo cable from the SPO2 Masimo board at J1, remove the NBP hose from the NBP input connector behind the input board.
4. Disconnect 2 plastic screws from the backside of the main board and remove the input panel assembly with recorder assembly and input board attached.
5. Remove 4 screws securing the patient input board to the input panel assembly.

6. Remove 4 screws from the recorder housing and remove the recorder from the input panel assembly for replacement.

7.9 Replacing the SPO2 Masimo Board

1. After monitor disassembly is performed, the SPO2 Masimo board can be removed by removing the one screw securing the assembly to the rear chassis and then sliding the assembly out of the rear chassis.
2. The SPO2 Masimo board can now be removed from the assembly bracket by removing the 3 plastic hold-down screws.

7.10 Replacing the Power Supply Board

1. After monitor disassembly is performed, the power supply can be removed from the rear of the chassis.
2. Remove P2 connector from the power supply board.
3. Remove 4 screws securing the power supply board to the chassis.

7.11 Replacing the Battery Charger Board

1. After monitor disassembly is performed, the battery charger board can be removed by carefully breaking the glue seal on top and bottom of charger board with a small screwdriver.
2. Slide the battery charger board out of the rear chassis.

7.12 Replacing Cracked Case Pieces

1. Obtain the replacement parts for the cracked case as appropriate (see chapter 9).

NOTE - It is important to specify the monitor serial number in order to get case pieces that match the monitor.

2. Disassemble the monitor according to the Monitor Disassembly Procedure.
3. Replace the damaged assemblies.
4. Re-assemble the monitor according to the Monitor Reassembly Procedure.

8. Accessories

The following table shows the accessories recommended by InvivoMDE for use with the Escort M8 Vital Signs Monitor.

WARNING - Use only recommended accessories with the Escort M8 Vital Signs Monitor. Using unrecommended accessories may result in damage to the monitoring equipment or in harm to the patient. Using unrecommended accessories may also void the warranty coverage.

ECG Accessories	
Part Number	Description
SHIELDED ECG Cables and Lead Wires	
9259	ECG Patient Cable 8 foot, Shielded, 5 lead, U.S. Domestic Color Coded.
9260	ECG Pinch 5 Lead Wires, 40 inch Shielded, U.S. Domestic Color Coded.
9261	ECG Snap 5 Lead Wires, 40 inch Shielded, U.S. Domestic Color Coded.
9259A	ECG Patient Cable 8 foot, Shielded, 5 lead, IEC Color Coded.
9260A	ECG Pinch 5 Lead Wires, 40 inch Shielded, IEC Color Coded.
9261A	ECG Snap 5 Lead Wires, 40 inch Shielded, IEC Color Coded.
UNSHIELDED ECG Cable and Lead Wires	
9201	ECG Patient Cable, 3 lead 10 foot, safety.
9331N	Neotrode II Neonatal/Pediatric Electrode with Pre-attached leadwires, 1 set of 3 lead safety wires with pre-attached electrodes per individual pouch. Allows visualization of skin under electrode. Highly resistant to electrode dry out. Designed for long term usage. Connection is a 0.060"/1.5mm Safety socket. Adhesion may be altered with water. Latex free. Box of 10 pouches (ECG Cable P/N 9201 required).
ECG Supplies	
9391	ECG Electrodes Adult, 3M #M2246 Red Dot Micropore w.prep, 25/box.
9330N	Huggables Electrodes, Neonatal - Pediatric. Perforated clear tape for comfort. Gel pocket stabilizes the electrode. Small size for easy placement. Low chloride gel for sensitive skin. 10 individual pouches, 3 electrodes per pouch, Latex free.
9221	Adapter to enable usage of Phillips (HP) ECG cables with the monitor.
9009	ECG/EEG Skin Prep Gel, 1 tube, 4 oz.

Accessories

Pulse Oximetry Accessories	
Part Number	Description
Masimo SET® SpO2 Sensors	
<p>Masimo Signal Extraction Technology (SET®) substantially eliminates false alarms without sacrificing true alarms. This technology is accurate during patient movement and is designed for accurate monitoring during low perfusion, intense ambient light and electrocautery interference.</p> <p>If the Patient monitor is equipped with Masimo SET®, use of the Masimo sensors and adapter cable will automatically enable the SET SpO2 technology.</p> <p>Product Note: Masimo Sensor Adapter Cable P/N 9289A or 9289B required for use with Masimo Reusable and Single Patient Adhesive Sensors.</p>	
9289B	Masimo Sensor Adapter Cable. Adapter cable required for use with Masimo Reusable and Single Patient Use SpO2 Sensors. To activate the SET monitoring feature, the monitor must be equipped with the Masimo SET technology. 12 foot length.
9289A	Masimo Sensor Adapter Cable. Adapter cable required for use with Masimo Reusable and Single Patient Use SpO2 Sensors. To activate the SET monitoring feature, the monitor must be equipped with the Masimo SET technology. 8 foot length.
9315	Masimo Reusable Adult Finger Sensor. Adult size reusable SpO2 finger clip. Cable P/N 9289B or 9289A required for use with monitor.
9315P	Masimo Reusable Pediatric Finger Sensor. Pediatric size reusable SpO2 finger clip. Cable P/N 9289B or 9289A required for use with monitor.
9315E	Masimo Reusable Ear Sensor. Cable P/N 9289B or 9289A required for use with monitor.
9310N	Masimo Adult SpO2 Sensor > 30 kg. Box of 20. Single Patient Adhesive Sensor. Cable P/N 9289B or 9289A required for use with monitor.
9310AN	Masimo Pediatric/Slender Digit SpO2 Sensor < 50 kg. Box of 20. Single Patient Adhesive Sensor. Cable P/N 9289B or 9289A required for use with monitor.

Pulse Oximetry Accessories	
Part Number	Description
Nellcor Adapters	
9398	Nellcor Probe Connection Adapter Cable (9 foot length) to enable use of Nellcor Sensors with the monitor. Includes Nellcor sensor adapter P/N 9472.
9472	Nellcor Adapter to enable use with the Nellcor sensors and InvivoMDE Connection Cable P/N 9398 (sold separately).

Non-Invasive Blood Pressure Accessories	
Part Number	Description
AIR HOSE. For use with the Escort M8™ Monitor.	
9010S	Single Lumen NIBP Air Hose. Quick disconnect fitting.
REUSABLE Single-Lumen. Infant to adult thigh. For use with the Escort M8™ Monitor.	
9080S	Adult BP Cuff. Large Arm. Circumference range 33 to 47 cm. Quick Disconnect Fitting.
9070S	Adult BP Cuff. Standard. Circumference range 25 to 35 cm. Quick Disconnect Fitting.
9060S	Pediatric BP Cuff. Circumference range 18 to 26 cm. Quick Disconnect Fitting.
9050S	Infant BP Cuff. Circumference range 10 to 19 cm. Quick Disconnect Fitting.
9040S	Small Infant BP Cuff. Circumference range 8.3 to 15 cm. Quick Disconnect Fitting.

Accessories

Temperature Accessories	
Part Number	Description
SureTemp® PLUS Temperature Accessories	
93001	SureTemp® PLUS Probe and Probe Well Kit, 9 foot Oral. Replacement Oral probe and well, blue kit (Welch/Allyn Part Number 02893-100)
93002	SureTemp® PLUS Oral Probe Well (Blue). Replacement Oral Probe Well (Welch/Allyn Part Number 02891-0000)
93003	SureTemp® PLUS Calibration Key. Calibration Key assembly for the SureTemp® PLUS Temperature Measurement System. Checks accuracy of the probe. (Welch/Allyn Part Number 06138-000)
93004	SureTemp® PLUS Probe Covers. Single Use, Disposable Covers. Box of 1,000. (Welch/Allyn Part Number 05031-101)
93005	SureTemp® PLUS Probe Covers. Single Use, Disposable Covers. Case of 5,000. (Welch/Allyn Part Number 05031-105)
93006	SureTemp® PLUS Probe Covers. Single Use, Disposable Covers. Case of 10,000. (Welch/Allyn Part Number 05031-110)
YSI Disposable Temperature Accessories	
9200B	Temperature Adapter Cable. Reusable (required for disposable probes). Not sterilized. Non-autoclavable.
9390B	Disposable Esophageal / Rectal Probe. Sterile, disposable vinyl probe with a flexible 3 foot lead. Adapter Cable P/N 9200B is required.
9390D	Disposable Skin Surface Sensor Probe. Sterile, disposable vinyl probe with a flexible 3 foot lead. Sensor comes with adhesive foam pad for ease in attachment to skin (1 inch diameter). Adapter Cable P/N 9200B is required.
YSI Reusable Temperature Accessories	
9390H	Reusable Esophageal/Rectal Probe. Rugged vinyl probe for adult or pediatrics. Non-detachable 10 foot vinyl covered cable plugs directly into monitor temperature jack. Gas sterilizable. YSI Series 400 compatible.
9390J	Reusable Skin Surface Probe. Stainless steel cup tapes to skin. Non-detachable 10 foot vinyl covered probe plugs directly into temperature jack. Gas sterilizable. YSI Series 400 compatible.

Miscellaneous Supplies and Accessories	
Part Number	Description
9055	Escort M8™ Rechargeable Battery 11.1V.
9180T	Thermal Array Recorder Paper. Box of 10 rolls.
HE103	Power Supply 1000240V replacement. For use with AS18 Power Cord.
AS18	AC Power Cord. Hospital Grade. 8 foot. UL an CSA approved.
Escort M8™ Manuals	
9665	Escort M8™ Operations Manual.
9566	Escort M8™ Service Manual.
Carts and Mounts	
9003L	Escort M8™ Mounting Bracket. Allows monitor to be mounted on an IV or similar pole, GCX roll stand (P/N 9003J) or GCX wall mount (P/N 9401L). Includes all mounting hardware.
9401L	Escort M8™ GCX Wall Mount. This polymount bracket installs on any wall and permits the monitor to swivel (allowing viewing from any angle) and smoothly tilt from 0 to 28 degrees (avoiding glare on the monitor and permitting easy access to controls). Variable height adjustment permits optimal vertical positioning of the monitor. Includes all mounting hardware but requires P/N 9003P Escort M8™ Mounting Bracket to be purchased separately.
9003J	Escort M8™ GCX Roll Stand. Allows monitor to be mounted on a rolling cart Mobile Stand. Sturdy, lightweight, ideal for applications where portability and space savings are important considerations. Features non-tip base with casters, handle and a basket for storage. All hardware is included but requires P/N 9003P Escort M8™ Mounting Bracket to be purchased separately.

9. Spare Parts

ZOE Medical Part Number	Description
<u>Major Assemblies</u>	
451-5011	Monitor Front Bezel Assembly
451-5012	Monitor Rear Case Assembly
451-5008	Input Panel Assembly
<u>Assemblies/Subassemblies</u>	
325-2404	Membrane Keypad/Switch Panel
325-0004	Optical Encoder (w/Rotary Knob)
279-3003	8.4" LCD Display
725-1000	Inverter (DC-AC) Board
210-5100-T	Main Board
410-2000	Power Entry Module (w/Line Filter)
725-0011	Power Supply Board
210-5103-T	Battery Charger Board
666-2002	11.1 Vdc Battery
210-5101-T	Input Board
320-0308	Speaker
210-5108	SPO2 (Masimo) Board
279-5000	Recorder Kit (w/Recorder Board, Printer, Roller)
451-5016	Recorder Door (w/o Label)
661-1002	Foot Pad
377-1003	16MB Compact Flash Memory
<u>Cable Assemblies</u>	
420-1001	FCC 31 Pos. Cable (w/Ferrite)
420-1516	Recorder Ribbon Cable
420-1515	AC Power Cable
420-1518	Masimo Power-Comm. Ribbon Cable
420-1002	SPO2 Input Cable

Spare Parts

ZOE Medical Part Number	Description
420-1508	Inverter Control Cable

10. Cleaning

The following table provides instructions about how to clean the Escort M8 Vital Signs Monitor and its accessories. Accessories should be cleaned after each use. Before cleaning please refer to the cautions listed below the table.

Part	Recommended cleaning method
Escort M8 Vital Signs Monitor. ECG Cables. TEMP Cable. SpO2 Cable. NIBP Cuff. NIBP Hose. Power Supply. Power Cord.	<p><u>Materials</u></p> <ul style="list-style-type: none"> • Enzymatic detergent such as ENZOL (US) or CIDEZYME (outside the US). • Distilled water. • Disinfectant solution (such as CIDEX OPA, or a 10% solution of household bleach (5.25% sodium hypochlorite) in distilled water). • Soft cloths and/or soft-bristled brushes. • Protective gloves and eyewear. <p><u>Procedure</u></p> <ol style="list-style-type: none"> 1. Turn off power and disconnect the unit from the AC power wall outlet. 2. Put on gloves and protective eyewear. 3. Prepare the enzymatic detergent according to the manufacturer's instructions, and also the disinfectant solution, in separate containers. 4. Apply detergent to product using a soft cloth. If material is dried on, allow to sit for 1 minute. 5. Wipe smooth surfaces with the cloth. 6. Use a soft-bristle brush on visibly soiled areas and irregular surfaces. 7. Remove detergent from product using cloth dampened in distilled water. 8. Repeat as necessary. 9. Apply disinfectant solution on affected area using a soft cloth. Allow product to sit for 5 minutes. 10. Wipe away excess solution and clean product again with cloth dampened in distilled water. 11. Allow 2 hours for drying.
SpO2 Sensor and Reusable YSI Temperature Probe	<p><u>Materials</u></p> <ul style="list-style-type: none"> • 70% Isopropyl Alcohol pad. <p><u>Procedure</u></p> <ol style="list-style-type: none"> 1. Remove sensor/probe from patient and disconnect from sensor/probe cable. Wipe off with alcohol pad. Allow sensor/probe to dry before placing it on a patient.
Disposable Temperature Probes and SpO2 Sensors	Intended for single use only. Refer to sensor/probe manufacturer instructions.

Cleaning

Part	Recommended cleaning method
<p>SureTemp® PLUS Temperature Probe</p>	<p>Wipe the probe and cord regularly with a cloth dampened with warm water and a mild detergent solution.</p> <p>As needed, clean the probe and cord with a 70% isopropyl alcohol solution, a 10% chlorine bleach solution or a nonstaining disinfectant.</p> <p>Do not immerse or soak the probe in any type of fluid.</p> <p>Do not use steam, heat or gas sterilization of the probe.</p> <p>Do not autoclave the probe.</p>
<p>SureTemp® PLUS Temperature Probe Well</p>	<p>Remove the probe well from the unit. Unplug the latching probe connector to prevent the SureTemp® PLUS system from consuming power while the probe well is being cleaned.</p> <p>Clean the inner and outer surfaces of the probe well by swabbing them with a cloth dampened with a mild detergent solution, a 70% isopropyl alcohol solution, a 10% chlorine bleach solution or a nonstaining disinfectant. Immerse the probe well in mild detergent solution if necessary.</p> <p>Do not use hard or sharp objects to clean the probe well. Hard or sharp objects can damage the probe well which could cause the SureTemp® PLUS system to fail.</p> <p>Do not use steam, heat or gas sterilization on the probe well.</p> <p>Do not autoclave the probe well.</p> <p>Thoroughly dry all surfaces before reassembling the instrument.</p> <p>Reconnect the latching probe connector to the thermometer. Ensure that the connector snaps into position.</p> <p>Reinstall the probe well in the monitor and snap the probe well into position.</p> <p>Insert the probe into the probe well.</p>

CAUTION - If monitor becomes accidentally wet during use, discontinue operation of the monitor until all affected components have been cleaned and permitted to dry completely. Contact your local InvivoMDE representative if additional information is required.

CAUTION - Always disconnect the Escort M8 Vital Signs Monitor from AC mains power before cleaning.

CAUTION - Do not use harsh chemicals for cleaning – in particular, do not use disinfectants that contain phenol as they can spot plastics. Do not steam autoclave, gas sterilize, irradiate, subject to intense vacuum, or immerse in water or cleaning solution. Be careful to avoid getting cleaning liquids into connectors or the monitor. If this occurs, allow the unit to dry in warm air for 2 hours, then check to make sure all monitoring functions are still working properly.

CAUTION - Take particular care when cleaning the NIBP cuff, NIBP hose, and NIBP connector on the Escort M8 Vital Signs Monitor to prevent fluid from entering the connectors. Fluid in the NIBP airway may affect blood pressure determination accuracy and damage the monitor.

CAUTION - Accessories that fall on the floor should be inspected for contamination and proper functionality. If contamination is observed, then this cleaning procedure should be followed.

CAUTION - The user has the responsibility to validate any deviations from the recommended method of cleaning and disinfection.

CAUTION - Do not reuse single use items.

11. Maintenance and Storage

The following table shows the recommended maintenance procedure for the Escort M8 Vital Signs Monitor and its accessories. These procedures should be carried out every 12 months and can be performed by qualified service personnel.

Alternatively, the unit may be returned to the factory. Before returning a Escort M8 Vital Signs Monitor for maintenance checks or repairs, please contact InvivoMDE Technical Service to get a return authorization number.

Phone: **(800) 331-3220**
 (407) 275-3220

If there is a failure in one of the checks, the unit must be returned to the factory for repair.

In order to perform some of these checks, the following equipment is needed:

- ECG/Respiration Simulator (e.g., Bio-tek Instruments Lionheart-3).
- SpO2 Simulator (e.g., Bio-tek Instruments Index-2).
- Blood Pressure Simulator (e.g., Bio-tek Instruments BP-Pump).
- Safety Analyzer (e.g., Bio-tek Instruments 505 Series)
- **SureTemp® PLUS** Calibration Key (Welch/Allyn Part Number 06138-000).

Monitor Function	Procedure
Mechanical Integrity	Check for cracks, abrasive edges and other signs of damage.
Front Panel Keys/Rotary Knob	<ul style="list-style-type: none"> • Verify turning the rotary knob clockwise and counter-clockwise allows the monitor to scroll to the right and left. Pushing the knob causes selection. • Setup key: verify access to Setup menu. • Alarms Setup key: verify access to the Setup Alarms menu. • Clear Trends key: verify access to the Clear Trends menu. • NIBP START/STOP key: verify NIBP measurements start and stop. • Trends key: verify access to the Trends menu. • NIBP Interval key: verify access to the Setup NIBP Interval menu. • Record key: verify recording strips start and stop. • Normal Screen key: verify return to “Normal Screen” from any popup menu. • Standby key: verify Standby mode. • Alarm Silence key: verify silencing of alarm.
Power LED	Verify that the green power LED is illuminated on the 3800 Vital Signs Monitor.
Battery Charging LED	Verify that the green charging LED is illuminated on the 3800 Vital Signs Monitor when plugged into mains power.
Speaker	Power-cycle the 3800 Vital Signs Monitor and verify that the power-up speaker test tones are generated. (One low-pitched tone, followed by one medium-pitched tone, followed by two high-pitched tones.)

Maintenance and Storage

Monitor Function	Procedure
ECG/Respiration	<ul style="list-style-type: none"> • Connect ECG leads to Patient Simulator. • Verify proper heart rate at 30 and 300 bpm (± 2 bpm or ± 1 %). • Verify proper respiration rate at 15 and 120 bpm (± 3 bpm).
SpO ₂	<ul style="list-style-type: none"> • Connect to Patient Simulator (select appropriate sensor type). • Verify proper SpO₂ value at 84% and 96% (± 2 O₂%). • Verify proper PR value at 30 and 240 bpm (± 5 %).
NBP	<ul style="list-style-type: none"> • Connect to Patient Simulator and take a NIBP measurement. • Verify proper NIBP value at 120/80 (+/- 5 bpm). • Enter NIBP Calibration Mode: • (Setup>Biomedical>Service>Password>NIBPCalibration>On>OK>Close). • Set the Patient Simulator to read as a pressure gauge. • Inflate the cuff to 250 +/- 5 mmHg. • • Do not allow system to remain pressurized and stable below 20 mmHg. The monitor will remove this pressure as a zero offset and this will affect the validity of the calibration check. • Verify that the NIBP parameter value is within +/- 2 mmHg of the simulator. • Release pressure. • Inflate cuff to 300 mmHg. • Verify that the pressure is automatically dumped at 300 +/- 30 mmHg. • Inflate the cuff to 150 mmHg. Allow cuff pressure to settle (thermal effect). • Verify that the pressure drops less than 4 mmHg in 1 minute. • Release pressure. • Inflate cuff to 50 mmHg. • Verify that the pressure is automatically dumped after 180 seconds. • Power cycle the monitor.
YSI Temperature	None (self-checking).
SureTemp [®] PLUS Temperature	Attach Cal key to monitor. Remove probe from well. Temperature should read 36.3 +/-0.1°C (97.3 +/-0.2°F)

Maintenance and Storage

Monitor Function	Procedure
Leakage Current	<ul style="list-style-type: none"> • Connect to Safety Analyzer. <p>WARNING – FOLLOW SAFETY INSTRUCTIONS AS INDICATED IN THE MANUAL FOR THE ANALYZER.</p> <ul style="list-style-type: none"> • Verify Patient Lead Leakage (to ground): < 10 uA. • Verify Patient Lead Leakage (inter-lead): < 10 uA. • Verify Patient Lead Leakage (mains applied to leads): < 50 uA. • Verify Leakage to ground (normal): < 500 uA. • Verify Leakage to ground (reversed polarity): < 1000 uA. • Verify Leakage to ground (neutral opened): < 1000 uA.
Di-electric Withstand	<p>WARNING – FOLLOW SAFETY INSTRUCTIONS AS INDICATED IN THE MANUAL FOR THE DI-ELECTRIC WITHSTAND TESTER.</p> <ul style="list-style-type: none"> • Connect ECG Leads and monitor power input to tester. • Apply 1500 Vdc for 1 second. No isolation breakdown should be detected. • Connect monitor power supply input and output to tester. • Apply 1500 Vdc for 1 second. No isolation breakdown should be detected.
Recorder	Verify strip chart recording of waveform data followed by a parameter snapshot.

In order to prevent the Escort M8 Vital Signs Monitor's risk current from increasing beyond safe limits, the ECG cable should be cleaned according to the instruction in the Cleaning section of this manual.

To place the Escort M8 Vital Signs Monitor back in service after maintenance has been performed, connect the Escort M8 Vital Signs Monitor to a wall AC outlet, ensuring that cables do not present a tripping hazard.

11.1 Battery Replacement

If the battery is no longer holding a charge, it may need to be replaced. This should only be done by qualified service personnel.

To replace the battery:

1. Purchase a replacement battery (see Accessories section for part number).
2. Power-off the monitor.
3. On the back of the monitor, disconnect the AC power cord.
4. If **SureTemp® PLUS** is installed perform the following (if not continue to step 5):
 - Remove the **SureTemp® PLUS** Probe and Blue Probe Well from the monitor.
 - Disconnect the **SureTemp® PLUS** connector from the connection located in the center rear of the monitor.
5. Remove the cover with the CE Mark as follows:
 - Hold the cover in place while removing the two screws from the top left and right of the panel.
 - Once screws are removed, carefully rotate the panel toward the AC power connector and lay flat on working surface.

Maintenance and Storage

6. Remove the battery by pulling on the black pull tab located on the right of the battery.
7. Insert new battery ensuring that the black pull tab is accessible for future removal.
8. Carefully reinstall back cover and screws.
9. (If **SureTemp® PLUS** is installed) Reconnect the **SureTemp® PLUS** connector to the back of the monitor and reinstall the Blue Probe Well and Probe.
10. Properly dispose of the old battery (see Disposal section).

WARNING - RECOMMENDED BATTERIES Only use batteries that are listed in the **Accessories and Spare Parts** chapters.

11.2 Storage

Storage Temperature	-20° C to 50° C
Storage Humidity	> 10% to < 80% non-condensing
Storage Altitude	0 to +9,000 m (0 to 29,520 ft)

CAUTION - The battery should be removed from the monitor if the monitor is to be stored for an extended period of time.

CAUTION - The monitor may not conform to all of its performance specifications if stored outside these environmental specifications or used outside of the environmental specifications in the Technical Data section of this manual.

11.3 Warranty

InvivoMDE warrants this product, other than its expendable parts, to be free from defects in materials and workmanship for a period of twelve (12) months from the date of original delivery to the buyer or to buyer's order, provided that same is properly operated under conditions of normal use, and that periodic maintenance and service is performed. This same warranty is made for a period of thirty (30) days on expendable parts. This warranty shall become null and void if product has been repaired other than by **InvivoMDE**, or if the product has been subject to misuse, accident, negligence or abuse.

InvivoMDE's sole obligation under this warranty is limited to repairing a product which has been reported to **InvivoMDE's** Technical Service Center during normal business hours and shipped transportation prepaid. **InvivoMDE** shall not be liable for any damages including but not limited to incidental damages, consequential damages or special damages.

This warranty is in lieu of any other warranties, guarantees or conditions, including merchantability or fitness for a particular purpose. The remedies under this warranty are exclusive and **InvivoMDE** neither assumes nor authorizes anyone to assume for it any other obligation in connection with the sale or repair of its products.

InvivoMDE PRODUCTS CONTAIN PROPRIETARY COPY WRITTEN MATERIAL. ALL RIGHTS ARE RESERVED BY InvivoMDE.

11.4 Password Control

To access the Setup Alarms or Setup System Menu, perform the following steps when presented with the Enter Password Menu:

Maintenance and Storage

- Set Dial 1 to 49.
- Set Dial 2 to 48.
- Set Dial 3 to 46.
- Select OK.

12. Disposal

The disposal of accessories such as electrodes, blood pressure cuffs, temperature probes, and SpO2 sensors should be carried out according to the manufacturer's recommendations.

















At the end of its useful life, the Escort M8 Vital Signs Monitor should be properly disposed of as well. In particular, the Escort M8 Vital Signs Monitor contains a lithium coin battery, an lithium-ion battery pack, and electronic circuit boards which should not be incinerated or exposed to extreme heat. See warnings at the start of this manual for further precautions.

Contact your local waste disposal agency for guidance on the proper recycling or disposal of these components.

13. Technical Data

General	
Dimensions	11.6"W x 7.5"H x 5"D (290mm x 188mm x 126mm).
Weight	6.25 lb (2.8 Kg).
Finish	IPX0 ABS.
Power Requirements	100 – 240 VAC, 0.7 A max.
Mains Frequency Range	50 – 60 Hz.
Power Consumption	11 watts nominal, 25 watts maximum (when charging battery).
Standards Conformance	UL 60601-1, FCC Part 15, CSA C22.2 No. 601.1-M90 IEC 60601-1, IEC 60601-1-1, IEC 60601-1-2, IEC 60601-1-4, IEC 60601-2-27, IEC 60601-2-30, IEC 60601-2-49.
Patient Risk Current (AAMI ES1-1993)	Electromedical Apparatus with Isolated Patient Connection. Meets the following limits: Enclosure Risk Current < 100 uA. Patient-applied Risk Current < 10 uA. Patient Isolation Risk Current < 50 uA. Earth Risk Current < 500 uA.
EMC Emissions Class	Class A.
Type of Protection (Electrical)	Class I.
Degree of Protection (Electrical)	Type CF, Defibrillation-proof.
Degree of Protection (Water)	No protection (IPX0).
Disinfecting Method	Per the instructions in the Cleaning section.
Degree of Safety (Flammable Anesthetic Mixture)	Not suitable for use in the presence of a Flammable Anesthetic Mixture.
Mode of Operation	Continuous.

Technical Data

Escort M8 Vital Signs Monitor Device Markings	
 0123	European CE Mark according to Council Directive 93/42/EEC.
 2003191	ETL Listed. Conforms to UL Standard 60601-1. Certified to CAN/CSA Standard CSA C22.2 No. 601.1-M90.
	For indoor-use only.
	Attention! Consult accompanying documents before using this device.
 05/2001	Manufacture date (month/year).
	Type CF Equipment (Defibrillation-proof).
	Antenna.
	Latex-free materials are used.
	Alternating Current.
	Single Patient Use Only. Do not reuse.
SN	Product Serial Number.
REF	Product Part Number.
	Off (For part of the equipment).
	On (For part of the equipment).
	Input.
	Output.
	Printer.
	Printer Paper Access.
P1/D1	Invasive Blood Pressure.

Escort M8 Vital Signs Monitor Device Markings (Continued)	
T1	Temperature Probe.
ECG/EKG	Electrocardiograph.
NIBP/NIBD	Non-invasive Blood Pressure.
SpO₂	Pulse Oximeter.
%SpO ₂	Percent Oxygen Pulse Saturation.
100-240 V~ 0.7A Max	Input power rating (100-240 Volts ac, 0.7 amperes max).

Battery	
Type	Lithium-Ion Rechargeable.
Discharging Time	4 hours (minimum), 5 hours (typical).
Charging Time	5 hours.
Charging Method	Battery is charged while monitor is connected to the AC mains supply.

Environmental	
Cooling	Convection (no fan).
Operating Temperature	59 to 104 °F (15 to 40 °C).
Storage Temperature	-4 to 122 °F (-20 to 50 °C).
Operating Humidity	>30% to <80% non-condensing.
Storage Humidity	>10% to <80% non-condensing.
Operating Altitude	0 to 9842 ft (0 to 3000 m).
Storage Altitude	0 to 29,520 ft (0 to 9000 m).

Display	
Type	Active matrix Color LCD.
Area	6.925 x 5.3 inches (8.4 inches diagonal). 176 x 134.6 mm (213.35 mm diagonal).
Matrix	640 x 480 pixels.
Pixel Pitch Dimension	0.27 mm.
Number of Channels	4
Sweep Speed	6.25, 12.5, 25 mm/s.
Display Mode	Eraser Bar.

Technical Data

ECG	
Accessories	3-lead cable, 5-lead cable. Refer to Section 15.
Input Connector	AAMI Standard ECG Input Connector.
Displayable Leads	3-lead cable: II. 5-lead cable: I, II, III, V.
HR Resolution	1 bpm (beats per minute).
Measurement Range	15 to 300 bpm.
Measurement Accuracy	± 2 bpm or $\pm 1\%$, whichever is greater.
Response Time	Step change from 80 to 120 bpm: < 7 seconds. Step change from 80 to 40 bpm: < 11 seconds. Per AAMI EC13-2002 4.1.2.1(f), response time is measured from the onset of the first QRS at the new rate to the time the measurement reads a value that is the original rate plus 63% of the change.
Report Interval	1 second.
HR Averaging Scheme	Average of the 10 most recent, valid R-R intervals, discarding the shortest and longest interval.
Time To Alarm - Tachycardia	< 10 seconds (5 seconds typical) for 150 bpm ventricular tachycardia or 3.5 Hz sinusoidal ventricular fibrillation.
Notch Filter Frequency	50Hz, 60Hz or Off.
Monitor Bandwidth	0.4Hz to 50Hz (-3dB).
Dynamic Range AC	± 20 mV.
Dynamic Range DC	± 300 mV.
Electrode Impedance	>2.5 Mohm at 10 Hz.
Defibrillation Protection	Complies with IEC 60601-2-27.
Pacer Pulse Detection	Lead II
Pacer Pulse Rejection	Rejects all pulses of amplitude ± 2 mV to ± 700 mV and duration 0.1 to 2 ms with no tail, per AAMI EC13-2002 4.1.4.1. Rejects all pulses of amplitude ± 2 mv to ± 700 mV and duration 0.1 to 2 ms with 10 ms time constant tail of < 2mV, per AAMI EC13-2002 4.1.4.2 (Method A). AAMI EC13-2002 4.1.4.3: 1.54 v/s.
Tall T-Wave Rejection	Rejects all T-Waves less than or equal to 120% of a 1mV QRS and a Q-T interval of 350 ms, per AAMI EC13-2002 4.1.2.1(c).
HR Response to Irregular Rhythm	HR is 82 bpm for a bigeminy rhythm consisting of 0.51 and 0.96 second R-R intervals. HR is 76 to 82 for a trigeminy rhythm consisting of 0.51, 0.81 and 0.96 second R-R intervals. HR is 76 to 80 for a frequent multifocal rhythm consisting of 0.63, 0.65, 0.75, 0.95 and 1.03 second R-R intervals.
Active Noise Suppression	RL drive (< 500 nA).
Pulse Tone	Yes.

Respiration	
Method	Impedance Pneumography.
Input Connector	Same as ECG.
Sweep Rate	Fixed at 6.25 mm/second.
Sensing Lead	II.
RR Resolution	1 bpm (breaths per minute).
Measurement Range	2 to 120 bpm.
Measurement Accuracy	±3 bpm.
Measurement Sensitivity	0.25 ohms (minimum).
Report Interval	1 second.
Bandwidth	0.17 to 3.3 Hz (-3dB).
Impedance Measuring Current	< 10 uA @ 44 kHz square wave across Lead II.
Pulse Oximetry	
Method	Absorption – Spectrophotometric (dual wavelength) (Functional oxygen saturation of arterial hemoglobin).
Input Connector	7-pin Limo connector. See Accessories for probe information.
SpO2 / PR Resolution	SpO2: 1 O2%. PR: 1 bpm (beat per minute).
Measurement Range	SpO2: 1 to 100%. PR: 25 to 240 bpm.
Measurement Accuracy	SpO2: from 70 to 100%: ±2% (O2%), < 70%: unspecified. PR: ±3 bpm (beats per minute).
Measurement Test Method	BioTek Instruments Index2 SpO2 Simulator.
Report Interval	1 second. Numeric values held < 30 seconds, per EN 865.
Pulse Tone	Yes (pulse tone pitch tied to SpO2 parameter value).
YSI Temperature	
Compatibility	YSI 400-series probes.
Input Connector	2-pin connector.
Display Units	°F and °C (user-selectable).
Measurement Resolution	0.1 °F (0.1 °C).
Measurement Range	32.0 to 122.0 °F (0.0 to 50.0 °C).
Measurement Accuracy	±0.1 °F (±0.1 °C) plus probe tolerance.

Technical Data

SureTemp Plus Temperature	
Compatibility	SureTemp Plus Series Probes
Display Units	°F and °C (user-selectable).
Measurement Resolution	0.1 °F (0.1 °C).
Measurement Range	96.0 to 105.0 °F (35.6 to 40.6 °C).
Measurement Accuracy	±0.2 °F (±0.1 °C) plus probe tolerance.
Non Invasive Blood Pressure	
Method	Oscillometric.
Input Connector	Single Lumen Hose (Quick-Disconnect fitting).
Cuffs Available	Infant, Pediatric, Small Adult, Adult, Large Arm. Refer to Section 15.
Derived Parameters	Systolic, Diastolic and Mean.
Resolution	1 mmHg.
Measurement Range	Systolic: 30 to 250 mmHg . Diastolic: 10 to 210 mmHg. Mean: 20 to 230 mmHg.
Measurement Accuracy	Systolic: Within 5 mmHg ±8 mmHg. Diastolic: Within 5 mmHg ±8 mmHg. Mean: Within 5 mmHg ±8 mmHg.
Pulse Rate Range	30 to 240 bpm.
Pulse Rate Accuracy	±5% or ±2 bpm, whichever is greater.
Update Interval	Upon measurement completion.
Measurement Time	30 seconds (typical), < 135 seconds (maximum).
Initial Cuff Pressure	160 mmHg (user-selectable over a range of 100 to 270 mmHg).
Repeated Cuff Pressure	Previous systolic + 40 mmHg.
Static Cuff Pressure Accuracy	±3 mmHg.
Overpressure Cutoff	290 ± 3 mmHg (normal means), 300 ± 30 mmHg (back-up).
Measurement Modes	Single Measurement or Auto (Interval) Measurement.
Auto Measurement Settings	Off, 3, 5, 10, 15, 30, 60, 120 minutes.
Recorder	
Chart Speed	22 mm/second.
Width	40 mm.
Paper Type and Size	Non-Grid Thermal Paper, 50 mm wide.
Resolution	800 dots/inch.